

# Centre Journal

Winter 2004/05



A publication of the Manitoba HVDC Research Centre Inc.,  
copyright © 2004, all rights reserved.

## Inside this issue:

<b>Optimization-Enabled PSCAD Transient Simulation</b>	1
<b>PSCAD Development Strong</b>	1
<b>PSCAD Users' Group Meeting</b>	2
<b>Prediction of Transmission System Protection Performance</b>	3
<b>LiveWire 2.2 Released</b>	6
<b>Notices and Upcoming Events</b>	6

## PSCAD Development Strong

PSCAD Version 4 continues to be a strong product and the ongoing development by the team at the Centre continues to bring new and innovative tools to the user base.

It has always been a very important part of the product to provide expert and timely support services to the users of PSCAD. To extend this effort one step further, we set out to create a web interface that allowed users to interact with one another in a more dynamic environment. This effort has resulted in a new PSCAD Forum website (<http://bb.pscad.com>) that allows users to share their collective experiences and ask questions to the community. The purpose of the Forum is to provide a mechanism that went beyond the basic support in areas where the answers may not be readily available from support but rather from other users.

*Continued on page 6*

## OPTIMIZATION-ENABLED PSCAD TRANSIENT SIMULATION

Electromagnetic transient simulation programs find numerous applications in the design of complicated nonlinear circuits, where they are used to accurately simulate the performance of a new design. With the level of nonlinearities increasing, analytical design methods find more limitations in practice and as such simulation-based methods are becoming more viable solutions.

The design procedure often requires several simulations before an optimal setting for the design parameters is obtained. To address this issue, simulation programs are equipped with search engines, such as the Multiple-Run component in the PSCAD/EMTDC, that enable successive simulations for a pre-specified (or sometimes randomly selected) group of parameter sets. With regard to the fact that transient simulation is a computationally intensive process, it becomes evident that design using conventional sequential or random search methods can be overwhelmingly intense in terms of computer resources required.

Optimization-enabled transient simulation is a powerful alternative, which combines the power of transient simulation in describing a nonlinear system with the power of an optimization algorithm in efficiently searching for the optimum. The basic idea in optimization-enabled simulation is to replace the unsupervised sequential (or random) search with an optimization algorithm, which intelligently selects parameter sets and steers the design towards the optimal parameter set.

As shown in Fig. 1, a parameter set generated by the optimization algo-

rithm is used in the transient simulation program, which simulates the network and evaluates its corresponding objective function [1].

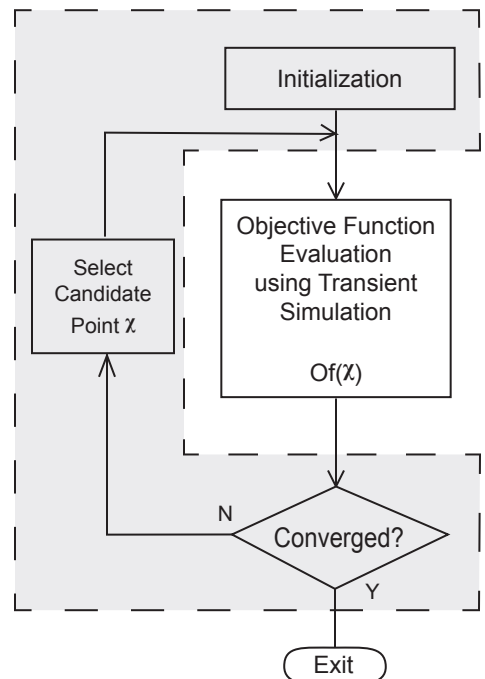

Fig. 1: Optimization-enabled transient simulation

The objective function is a mathematical representation of the design specifications and shows a figure of merit for the current parameter set. The optimization algorithm uses the objective function evaluation to generate a parameter set with a better figure of merit.

The most prominent feature of this tool is its capability of finding the optimal parameter set even under situations where the complexity of the network prohibits an analytical formulation of the objective function in terms of the design parameters. The intelligence

*Continued on page 2*

Transient Optimization: continued from page 1 incorporated into the design through the use of an optimization algorithm leads to orders of magnitude reduction in the number (and hence the intensity) of the simulations and also improves the accuracy of the results.

### Example Case

In this section, the design procedure using optimization-enabled transient simulation is demonstrated through an example. The circuit under

1. the dc filter elements ( $L_{dc}, C_{dc}$ ), to minimize the ripple on dc side voltage and current;
2. the gain and time constant of the PI controller ( $K_p, T_i$ ), to obtain smooth load current dynamics with little overshoot and minimum steady state error; and
3. the switching frequency of the IGBT ( $f_{sw}$ ), to minimize the switching losses.

The above objectives are formulated in

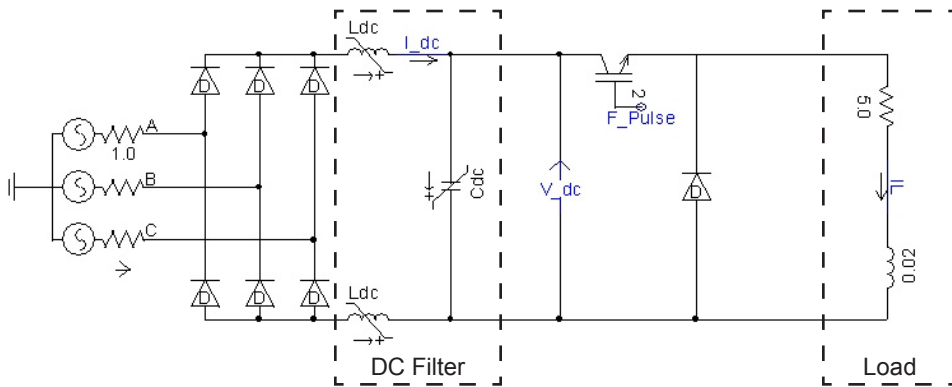

Fig. 2(a) Schematic diagram of the dc power supply

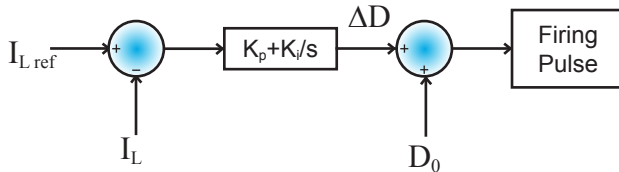

Fig. 2(b) Load current control system

consideration is a dc power supply, as shown in Fig. 2(a). In this circuit, a diode bridge is used to rectify the three-phase ac source and produces (after filtering) an unregulated dc voltage. The IGBT switch is then used to regulate the voltage across the load and thereby to control the load current. Regulation of the load current to a reference value is usually done through a closed loop control system, as shown in Fig. 2(b). The control system uses the error between the actual and the reference values of the load current to adjust the duty cycle of the switch, which is turned ON and OFF according to a PWM scheme [2].

The objective of the design is to determine the optimal values for:

the following objective function.

$$OF(K_p, K_i, f_{sw}, L_{dc}, C_{dc}) = W_1 \cdot ISE_1 + W_2 \cdot f_{sw} + W_3 \cdot ISE_2$$

where  $ISE_1$  and  $ISE_2$  are the partial indices used to penalize the deviation in the load current dynamic response and the dc side quantities [1]. The indices are designed such that a closer match between the actual and the reference values results in a smaller value for the index. The overall goal of the design is therefore to find a parameter set that minimizes the objective function (OF) given above. The weighting factors  $W_i$  are used to signify the relative importance of the design specifications.

Continued on page 5

## PSCAD Users' Group Meeting

Twenty PSCAD users representing twelve North American organizations met at the Historic Nassau Inn



Delegates on Tour at the Princeton Plasma Physics Laboratory, Princeton, NJ, hosted by Ray Camp and Charles Neumeier of the PPPL

in downtown Princeton, New Jersey on June 21 & 22 this past summer to participate in the first North American PSCAD Users Group Meeting.

This collaborative Users Meeting included end-user presentations by Florida State University (Center for Advanced Power Systems), RTDS Technologies, EPRI-PEAC, Princeton Plasma Physics Lab, the University of Manitoba Power Systems Group, as well as the development team of the Manitoba HVDC Research Centre.

An Advanced Topics PSCAD course was held on the second day followed

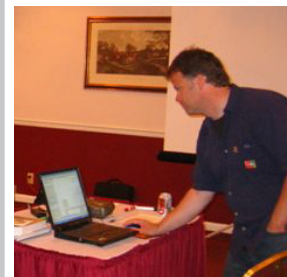

by a tour of the Princeton Plasma Physics Laboratory, the second largest consumer of electricity in the State of

New Jersey (the Lab consumes power for 300 ms every 15 minutes in order to generate 1.5 Million degrees F. of heat to study the behaviour of fusion energy). The power system is modeled and simulated using PSCAD.

Any persons interested in participating in the next 2005 PSCAD Users Group Meeting are encouraged to contact [info@pscads.com](mailto:info@pscads.com) to receive further information.

by Paul Buchanan

## PREDICTION OF TRANSMISSION SYSTEM PROTECTION PERFORMANCE

### INTRODUCTION

The transmission system operated by SESCo (the utility in Sarawak) comprises of 780 km of double circuit 275 kV overhead lines (Fig 1). These form a radial network from Tudan in the North East, via the main power generation plant at Bintulu, on to the largest load centre, the state's capital city of Kuching. Generation at Kuching is insufficient to meet local demand, which necessitates a high level of reliability on the single 275 kV transmission line

The protection scheme was thoroughly proven prior to its introduction by conjunctive tests in the manufacturers' works. Since then, the power system has developed significantly. The work reported here was undertaken to enable the performance of the protection to be assessed under present conditions. The model also allowed some past incidents, where the protection response was not entirely as expected, to be examined. The PSCAD model will continue to be used by SESCo to

included. At 132 kV, all lines less than 15 km are represented by coupled PI sections.

The SESCo system contains eight 275/132 kV auto-transformers. Each auto-transformer has a 33 kV delta connected tertiary winding. An auto-transformer model was not available in the PSCAD master library. Thus, a new auto-transformer model was developed based on three mutually coupled coils. Two coils form the auto connection and the third coil is the tertiary winding. The +ve sequence three winding star equivalent circuit parameters of the auto-transformer were converted to leakage reactance terms between each pair of windings in the three mutually coupled coils [2]. Additional inductance was inserted in the delta connected tertiary to adjust the zero-sequence impedance of the three-phase auto-transformer model. The accuracy of the auto-transformer model was confirmed by replicating the positive sequence, and zero sequence short circuit tests normally performed by manufacturers [3].

The generators in the network were modelled using the PSCAD synchronous machine state variable model [4]. As AVR's respond quickly to system disturbances, they are included in the model. Turbine governors, which have a slower response, are not included. System loads were lumped at each 33 kV substation.

As the model solves the system equations in the time-domain, it automatically allows for changes in the system admittances when circuit breakers operate. This makes the model ideal for studying transient switching operations, such as sequential operation of circuit breakers, and single pole auto-reclosing schemes.

### MODEL VERIFICATION

The accuracy of the model was assessed by predicting the transient waveshapes for historical faults for which disturbance recordings were

*Continued on page 4*

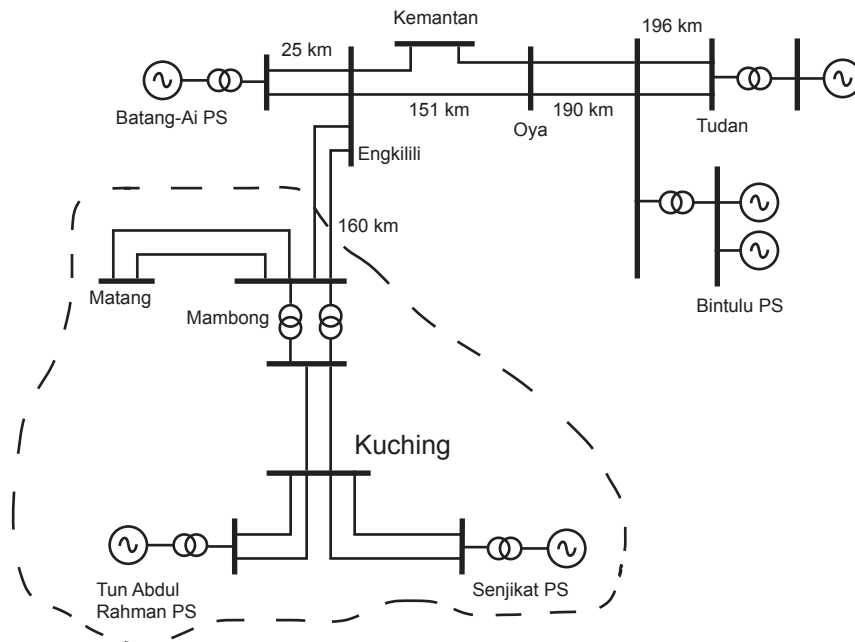

Figure 1: SESCo transmission system

between Bintulu and Kuching. The performance of the protection is crucial in achieving this reliability, particularly when considering that Sarawak is in a region of high isokeraunic activity which results in a significant number of single- and double-circuit faults.

The nature of the SESCo system places demands on the protection that are onerous, for example, fault levels are generally low and fault resistance high. In addition, correct phase selective tripping is crucial for the successful operation of the single pole auto-reclosing scheme. A wide range of generation patterns further increases the demands on the protection.

investigate the impact of future changes to the system on the protection.

### SYSTEM MODELLING

All 275 kV circuits in the network have been modelled using the frequency dependent (phase) model. The parameters of the line are calculated based on the conductor sizes and their geometric spacing on the transmission towers. All inductive and capacitive coupling effects between the individual phases of each circuit, and coupling between circuits on the same transmission tower are therefore included in the network model. Phase transpositions and fixed compensating reactors are



*Protection Performance: continued from page 3*

available. Both high and low resistance faults were considered, as well as single and double circuit faults. The fault location and impedance, and circuit breaker opening sequences were identified from the disturbance recordings. The central despatch record was used to establish the power flows and generation pattern before each fault occurred. This information was programmed into the model.

Good correlation between the measured and predicted currents (and voltages) for several high and low resistance historical fault recordings give confidence in the ability of the model to predict the transient performance of the system.

A sliding fast fourier transform (FFT) is used to convert the time domain waveshapes predicted by the simulation to the frequency domain, allowing the calculation of the instantaneous variation of the components of voltage, current and impedance. This provides additional information, which would not normally be available from a conventional steady state, phasor domain short circuit/fault flow calculation.

## USE OF MODEL FOR PROTECTION SYSTEMS

It is the intention that the model be used to analyse several aspects of protection performance, including:

- examination of actual protection response following system incidents,
- studies of the effects on protection performance of changes to the primary system, as well as determining the protection requirements of new circuits, and
- optimisation of protection settings.

One past incident that has been analysed is a double circuit fault on Batang Ai – Engkilili circuits; Red phase to earth on one circuit, Blue phase to earth on the other.

This fault is a good example of the usefulness of the model. The lines are protected by two sets of distance relays in blocking scheme mode;

utilising relays with significantly different impedance characteristics from different suppliers. The fault combination meant that the Batang Ai relays were presented simultaneously with a forward and a reverse fault condition. On the day, the two sets of protection performed differently. Also, while the fault on one circuit was cleared correctly (single pole) and auto-reclosing was successful, tripping at Engkilili on the other circuit was three pole. Use of the model enabled a detailed analysis to be carried out, by readily simulating the sequential tripping that actually occurred together with the high speed single pole reclosing. Such a detailed analysis would have been difficult using traditional techniques.

An initial screening check was made by plotting the relay characteristic onto an impedance (R-X) diagram and superimposing the fault impedance determined from the model results. With cross-polarised relays, the source impedance was assumed to be zero. When the fault impedance fell well within the characteristic, operation was deemed to be assured. However, when the fault was close to the characteristic boundary, a more rigorous check was made by applying the voltage and current derived from the model to the relay manufacturers' equations.

## DIRECTIONAL EARTH FAULT PROTECTION

Directional earth fault protection schemes (overreaching and blocking) are generally stable from the point of view of current sensitivity, since most relays are designed so that the reverse looking sensor is more sensitive than the forward looking. However, in the case of voltage, there is no such inherent "grading" hence the need to check the levels. The PSCAD model enables a thorough examination of the voltage conditions for all expected operating scenarios. A routine was written which readily allowed the voltages and currents to be computed for incremental changes in fault resistance to optimise the protection design and settings.

Another use of the model is to play

its output via a relay test (such as the RTP – Real Time Playback or other) set into relays that are known to be healthy and in this way confirm whether or not the protection performance was correct, or to predict the performance of a proposed circuit addition. A similar approach was described by the UK's National Grid Company and Strathclyde University [6].

## CONCLUSIONS

This paper presents a detailed EMT model of the SESCO 275 kV transmission system. The model has been verified using historical disturbance recorder traces. The model allows the transient performance of the system during sequential switching operations, such as single pole auto-reclosing, to be studied.

The model has been successfully used to assess the performance of the protection system for a wide range of system operating conditions and faults. It has also been used to examine a number of past events.

As the SESCO system is modified and extended, the model will be developed to reflect these changes. This will allow SESCO protection engineers to assess the effects of system changes on the protection.

by  
K.S. Smith, D.C Humphreys, K. Lawton  
Mott MacDonald, UK  
www.mottmac.com  
and  
N.M. Vong, Y.P.Yong, J. Eng  
SESCO, Sarawak, Malaysia  
www.sesco.com.my

*Editors note:*

- 1) *Subsequent to this study, a new auto-transformer model was developed and is now available in PSCAD V4.1*
- 2) *For the full text of this paper, please contact K.S. Smith on the PSCAD Forum (user id ken\_smith).*

Transient Optimization: continued from page 2

Table I (to the right) shows the results obtained from the optimization-based design for an operating point of 45 A. The design is carried out in less than 300 simulation runs, whereas a similar design using the conventional Multiple-Run approach with a coarse grid of 10 steps for such a problem with 5 variables requires  $10^5 = 100,000$  simulations.

Figure 3 below shows the load current dynamics and the dc side voltage and current waveforms for the initial parameter set, as well as for the optimized parameters. It is observed that the optimization has successfully resulted in a much smoother load current and has reduced the ripple on the dc side quantities as well. It should also be noted that the optimized switching frequency is more than 50% less than its initial value, which translates into a significant reduction of the switching losses.

### Current Status

The concept of optimization-enabled transient simulation has been implemented in the PSCAD/EMTDC and is now available in the Version 4.1 of the program. The optimization algorithms incorporated are the Simplex method of Nelder and Mead, Hooke-Jeeves and Golden Section. The algorithms are suitable for nonlinear single- and multi-variable optimization problems; inclusion of other methods, such as the Genetic Algorithms and gradient-based optimization methods is currently under consideration, and will be available in future releases.

by  
 Dr. S. Filizadeh and Dr. A.M. Gole  
 Department of Electrical and  
 Computer Engineering, University of  
 Manitoba

### References

- [1] A. M. Gole, S. Filizadeh, R. W. Menzies, P. L. Wilson, "Optimization-enabled electromagnetic transient simulation," *IEEE Trans. Power Delivery*, accepted.
- [2] N. Mohan, T. M. Undeland, W. P. Robbins, "Power Electronics: Converters, Applications, and Design", 3<sup>rd</sup> ed., New York: Wiley, 2003.

Table I - Optimization Results

Optimization Parameters					
	$K_p$	$K_i (1/T_i)$	$f_{sw}$ (Hz)	$L_{dc}$ (mH)	$C_{dc}$ ( $\mu$ F)
Initial value	2.0	90.0	2000	50.0	150
Optimized value	1.83	101.3	819.9	5.5	172.4

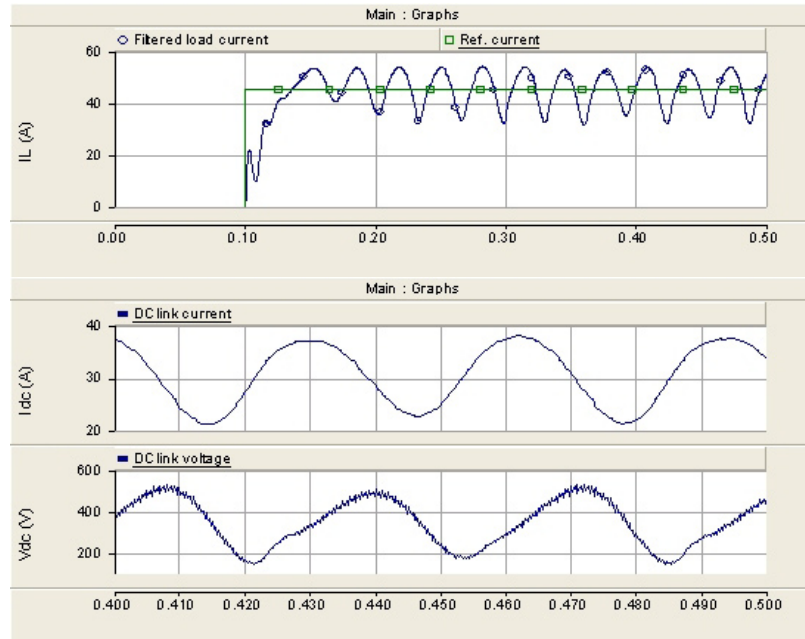

Fig. 3(a) Response of the system for the initial parameter set

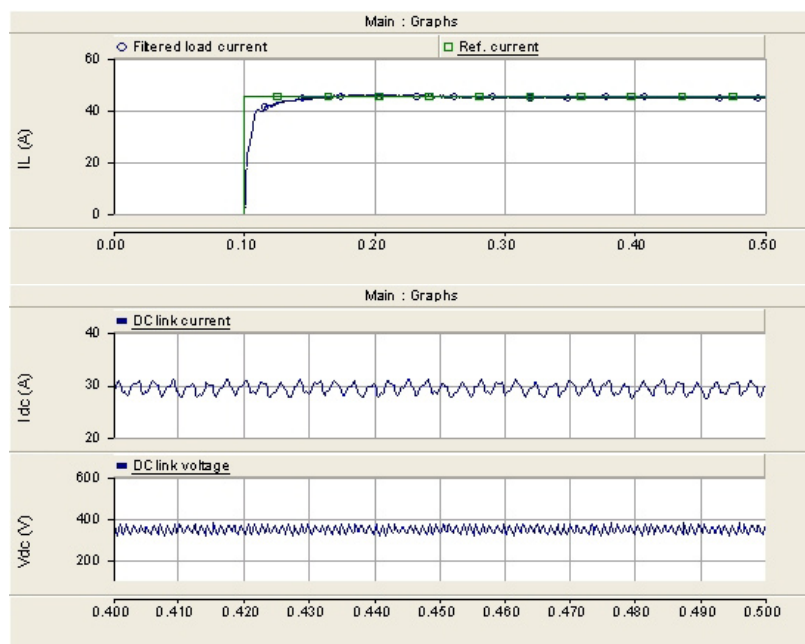
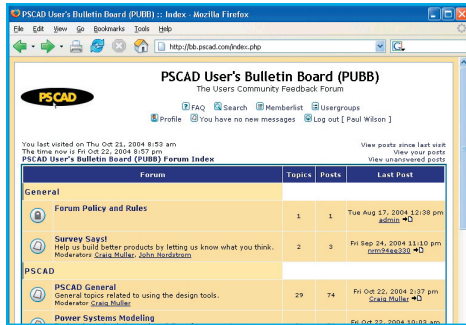

Fig. 3(b) Response of the system for the optimized parameter set

Strong: continued from page 1



In August, the Forum was launched and immediately drew a large audience of registered users. The site is moderated by selected members of the development team, support staff and other expert users in the community. We invite you to join with us on the site and share your experiences with others on discussions, simulation and research topics.

Development of PSCAD has been steady since the release of version 4.1 earlier in May. New components and tools are in the works for potential future releases. Some of the changes include enhanced drag and drop capabilities, new display components, navigational tools and unit system sup-

port. In addition to this, the team has been hard at work on a much larger project that will bring a new generation of PSCAD. This project, nicknamed "neXus," is designed to bring important but different study tools together into a single representation. Using a single system will allow engineers to compare and transfer information between the two solutions transparently and provide a powerful verification tool on larger systems. In addition, the new user interface design will make the development of transients simulation quicker and easier than in the past.

by  
Craig Muller  
PSCAD Development Manager

### Announcing PSCAD V4.1.1

All PSCAD Version 4 users with a current maintenance contract or warranty coverage can download V4.1.1 free of charge. PSCAD V3 or V2 users wishing to upgrade to the new Version 4, please contact us at email [upgrade@pscad.com](mailto:upgrade@pscad.com).

### LiveWire V2.2 Data Analysis Software Released

For those of you who don't know what LiveWire is, it is the ideal data analysis program for scientists and engineers who want to visualize and analyse unlimited amounts of data.

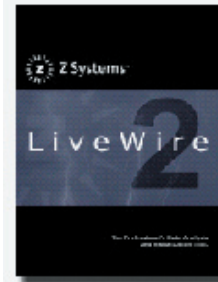

LiveWire is an excellent complement to PSCAD and replaces the Mulptot application that was once bundled with PSCAD/EMTDC Version 2. LiveWire sup-

ports the importation and exportation of industry standard data file formats, such as COMTRADE, EMTDC, and the newly added PSS/E files. If you desire, LiveWire even supplies you with the means to generate data from user-defined equations and import/export data from other applications using the clipboard.

#### What's new in Version 2.2?

- Improved support for Version 2 EMTDC and COMTRADE output data files.
- Automatic grouping of EMTDC output data in the data tree.
- Import for PSS/E output data files.
- Intelligent data importation support for file formats that are not directly supported (.out, .dat, .mat, .log, etc).
- Improved curve math/equation generator.

LiveWire 2.2 is available for evaluation download from [www.pscad.com](http://www.pscad.com). It will also be found on PSCAD Version 4.1.1 CDs. Any questions.. contact [info@pscad.com](mailto:info@pscad.com).

Mark Kulchyski, Z Systems, Inc.  
[mark@zsystems.mb.ca](mailto:mark@zsystems.mb.ca)

### The Manitoba HVDC Research Centre will be participating in the following upcoming events:

#### PowerCON 2004

IEEE 2004 International Conference on Power System Technology, Singapore  
November 21-24.

#### PSCAD V4.1 Seminar, Malaysia

Concorde Hotel Shah Alam, Selangor, Malaysia, contact [info@pscad.com](mailto:info@pscad.com) to register.  
November 26, 2004

#### Power Electronics Technology Conference

November 16-18, Chicago, USA, (hosted by Magsoft Corporation)

#### 2004 European Wind Energy Conference

November 22-25, 2004, London, UK, (hosted by CEDRAT S.A.)

#### PSCAD Version 4 Training Courses

Nayak Corp., Princeton, NJ, January, 2005  
Contact: [om@nayakcorp.com](mailto:om@nayakcorp.com)

February 13-16, 2005, Winnipeg, Canada  
Contact: [sales@pscad.com](mailto:sales@pscad.com)

**We look forward to seeing you!**

Copyright © 2004, all rights reserved. The Centre Journal is distributed free of charge and is posted electronically at <http://www.hvdc.ca>. If you would like to receive a copy of the Centre Journal, please send us an email to [info@hvdc.ca](mailto:info@hvdc.ca).

**Download PSCAD 4.1.1  
at  
<http://www.pscad.com>**