



PSCAD Cookbook

Load Flow Studies

Manitoba HVDC Research Centre

a division of Manitoba Hydro International Ltd.

211 Commerce Drive

Winnipeg, MB R3P 1A3, Canada

www.hvdc.ca

Written for v4.5 and 4.6
Revision 1, January 3, 2018

Contents

11.	LOAD FLOW STUDIES	1
11.1	INITIALIZING A LOAD FLOW.....	1
11.2	LOAD FLOW ANALYSIS.....	5

11. Load Flow Studies

11.1 Initializing a Load Flow

Motivation

PSCAD can also be used for Electromagnetic Transient (EMT) type of application. To perform a study like load flow it is crucial that the power grid is initialized properly. This application note addresses the various methods used to model and initialize the Electromagnetic Transient (EMT) network to a specific power flow. Load flow study is done to solve a network's steady-state requirements. In addition to this, dynamic system response depends on the operating conditions (i.e. load flow) of the power system prior to the events.

Background

Simplified ac systems can be represented by AC voltage sources of the same frequency connected through a reactance X in series as shown in Figure 1.

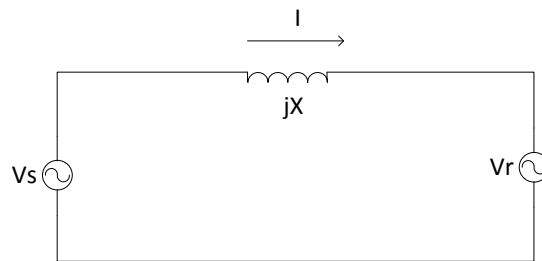

Figure 1: Simplified AC System

Vr is assumed to be the reference voltage with its phase angle to be zero and Vs is the source voltage with a phase shift of 'angle δ '. The load flow in any ac system is governed by the following general equation

$$P_R = \frac{V_s V_r}{X} \sin \delta \quad (1)$$

$$Q_R = \frac{V_s V_r \cos \delta}{X} - \frac{V_r^2}{X} \quad (2)$$

Equation one suggests that the real power flow is dependent on the difference between the phase angles of the source and reference voltage and not on their magnitude. On the other hand reactive power at the receiving end is related to the difference ($V_s - V_r$) between the voltage magnitudes.

A simple method for initialization of load flow for PSCAD

Assuming the load flow solution for a power system is available in a Load Flow Analysis (LFA) programs, the following steps may be taken to initialize the power system in PSCAD.

Do the following in LFA program:

- 1-** Identify the area that is required to do EMT studies. Identify the buses that connects the area with the rest of circuit (nearby buses).
- 2-** Replace the nearby buses with voltage source and define the active power and voltage magnitude for them through the load flow obtained for original power system.
- 3-** Redo the load flow for the new power system. In the new circuit the nearby sources are replaced by equivalent voltage sources that have same active power and voltage magnitude. When the load flow is done for the new circuit the reactive power and the angle can be calculated. Note that the reactive power range should be proximate to the reactive power obtained from the original circuit.
- 4-** Now for the new circuit the active and reactive powers, voltage magnitude and phase angles (4 parameters) are known.

Do the following in PSCAD:

- 1-** Create the same circuit in PSCAD for the new circuit we have in LFA program.
- 2-** Model the voltage sources as " At the terminal" and put the values for the four parameters obtained from LFA program as the terminal conditions for each voltage sources as shown in Figure 2.

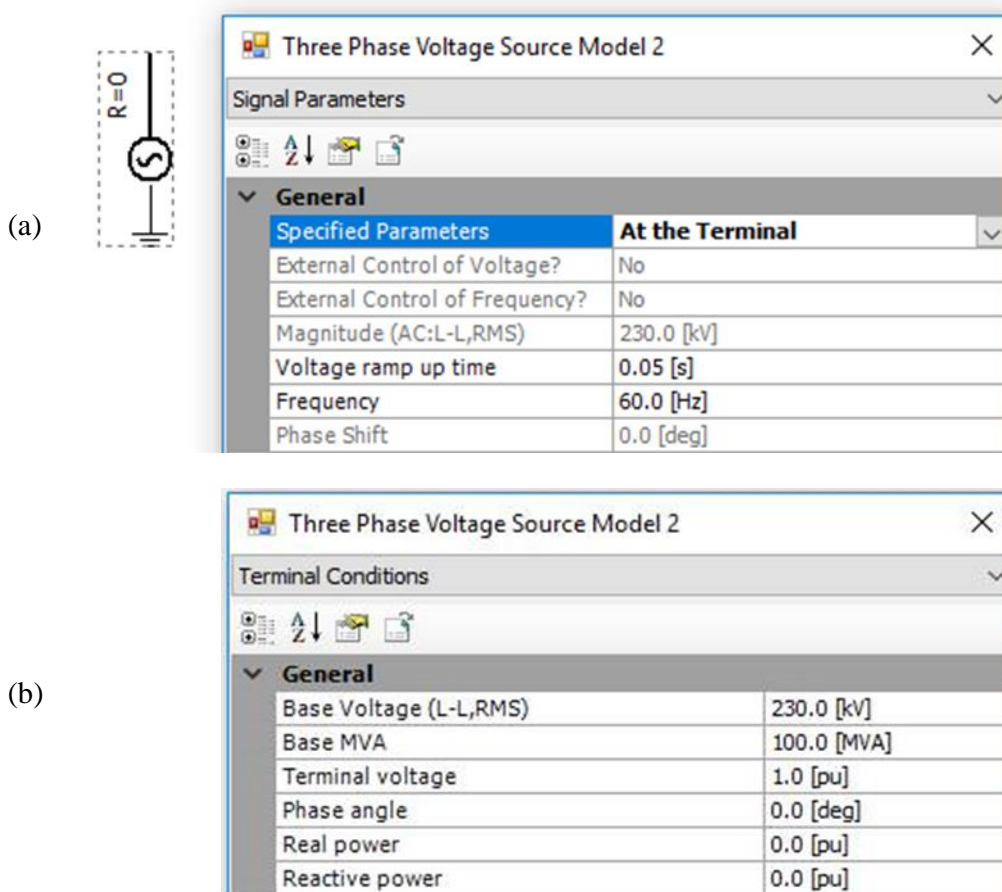

Figure 2: Modeling the equivalent voltage sources in PSCAD. (a) The voltage source is modeled at the terminal (b) the terminal conditions i.e. Terminal voltage, Phase angle, Real power and Reactive power are entered

The impedance of the equivalent sources can be identified by the following steps:

Do this in LFA program:

- 1- As shown in Figure 3 identify the nearby buses

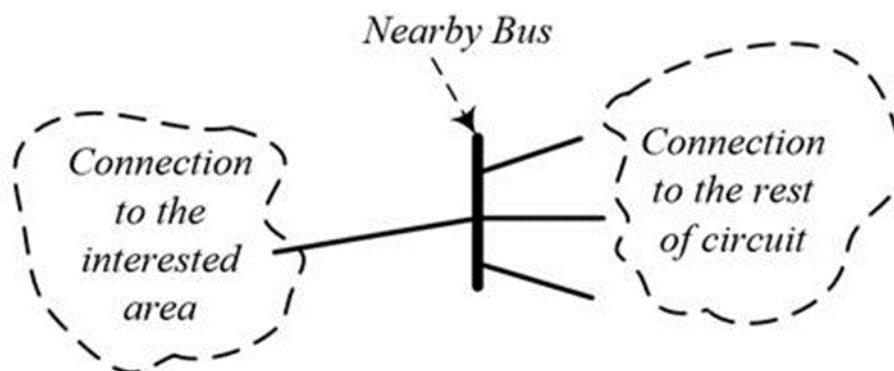

Figure 3: Identify the nearby buses connected to the interested area.

- 2- Disconnect the interested area that we want to do the EMT studies and apply a solid three-phase to ground fault as shown in Figure 4. Calculate the impedance of the bus during the fault (Z_{eq}).

$$Z_{bus} = \frac{V_{bus}}{\sqrt{3}I_{fault}} \quad (3)$$

where V_{bus} is the line to line rms voltage and I_{fault} is the fault current.

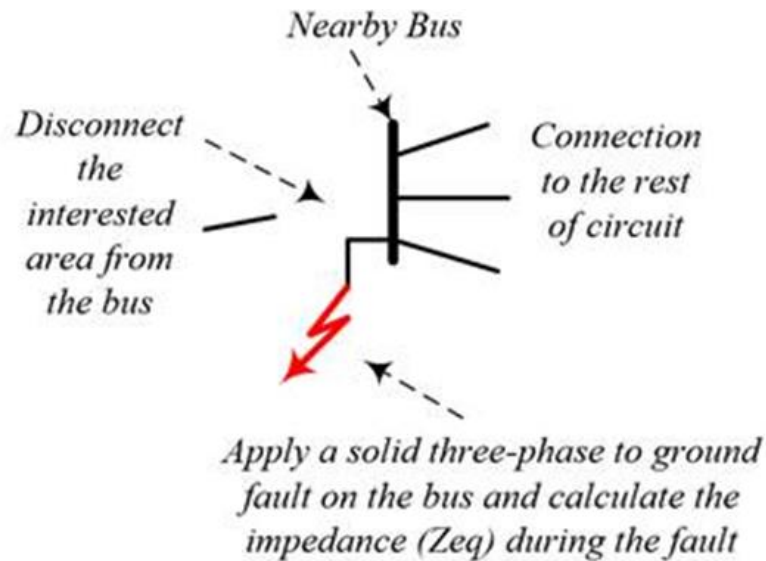

Figure 4: Apply a solid three-phase to ground fault and calculate the equivalent impedance.

Do this in PSCAD and LFA program (when making the equivalent circuit and replacing the rest of circuit by voltage sources):

As shown in Figure 5, replace the rest of circuit by a voltage source and equivalent impedance that calculated from the above simulation in LFA program.

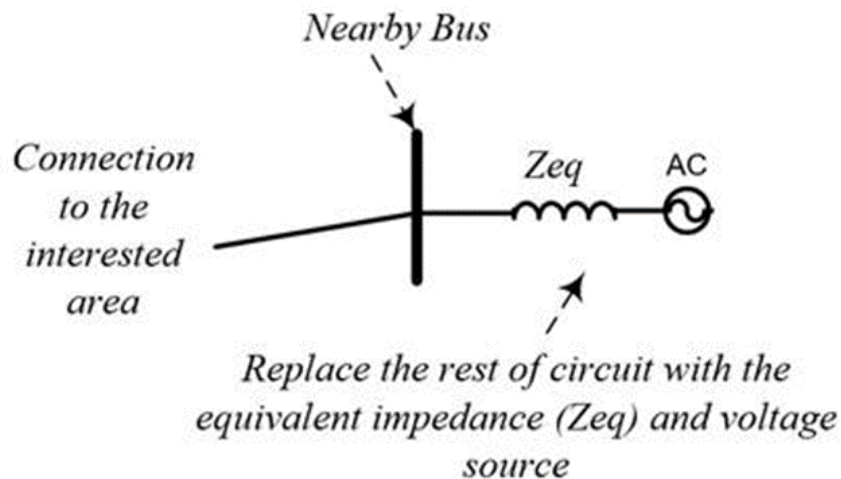

Figure 5: Replace the circuit with the equivalent voltage source and impedance.

11.2 Load Flow Analysis

Motivation

Load flow studies can be used to study the optimum load flow and contingency analysis of a power system. By determining the voltage magnitude and angles at every bus in the system, the power flows can be calculated between buses and hence reactive power output required by each generator.

PSCAD simulation 1

Refer to PSCAD case: *Load_Flow_01.pscx*

Case 1: Network Equivalence modeled as an ideal source

In this example there are four buses used to illustrate the load flow initialization. The two generator buses (BUS1 and BUS 3) are modeled as ideal voltage sources ($R=0$). The Thevenin equivalent voltage and the phase for these models serve as the input to PSCAD. The network is also modeled as an equivalent source, the terminal voltage and phase angles are obtained from a LFA program. The load bus is modeled as passive elements.

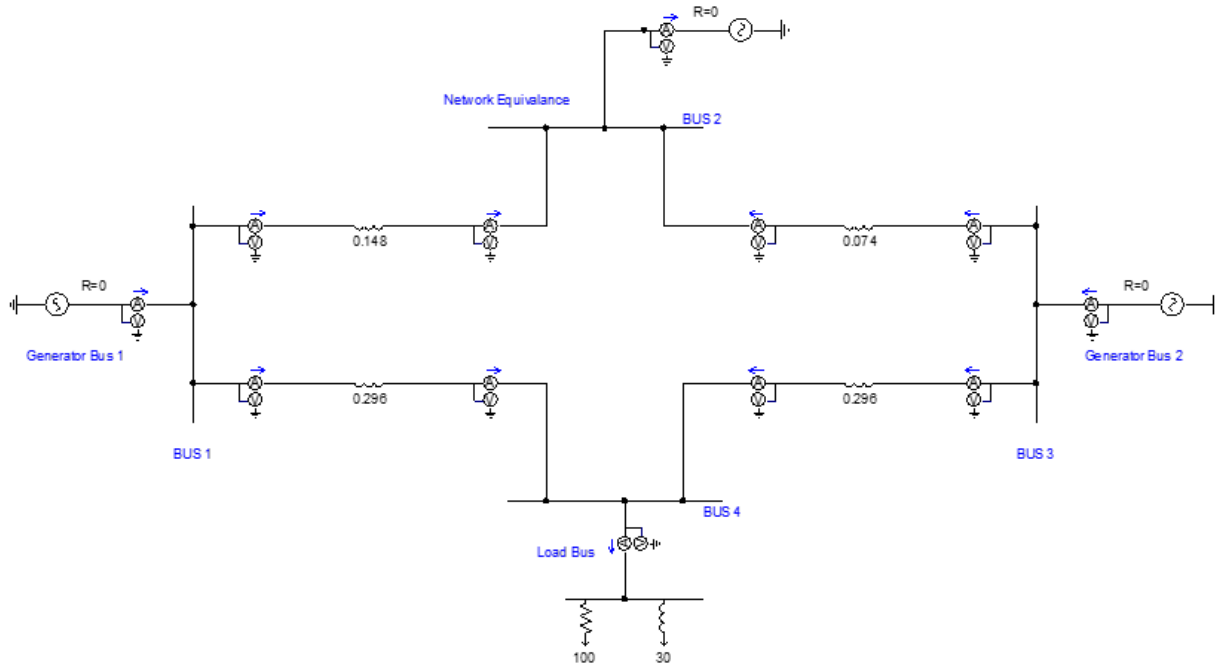

Figure 6: Basic load flow (see PSCAD case Load_flow_01)

Table 1 shows the various buses and their terminal voltage and phase angle.

Table 1: Buses and their Terminal Voltage and Phase Angle when network equivalent is modeld as ideal source

BUS	Equivalent voltage	Phase
1	230	0
2	230	-7.271
3	230	4.863
4	221.6	16.69

The transfer of real and reactive power between the different buses is in accordance with the power flow equation (Eq 1 & 2) and is listed in Table 2.

Table 2: Buses and their real and reactive powers when network equivalent is modeld as ideal source

BUS	Real Power (P)	Reactive Power (Q)
1-2	120	-7.623
1-4	27.14	15.89
3-2	398.5	-42.36
3-4	65.68	11.95

Figure 7 and Figure 8 show the apparent power transferred to BUS 2 (network equivalence) and to BUS 4 (load bus).

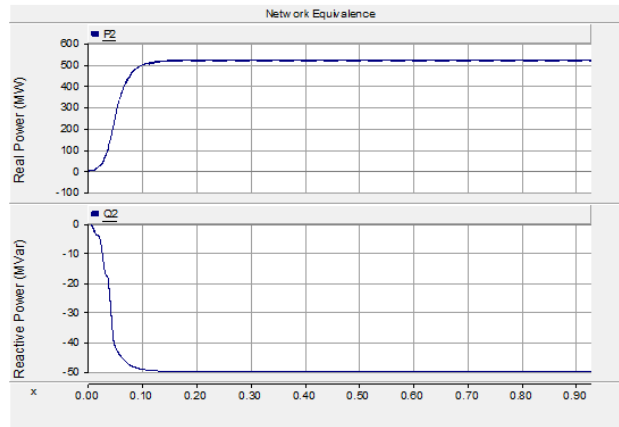

Figure 7: Network Equivalence power flow

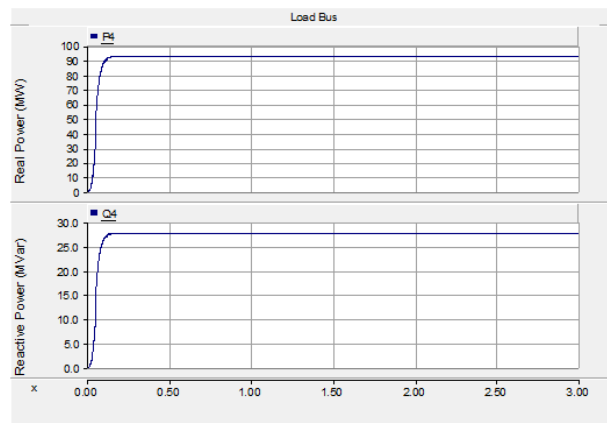

Figure 8: Load Bus active and reactive powers

Case 2: Network Equivalence modeled as a non-ideal source

In this case the network equivalence is no longer represented as an ideal voltage source; the source impedance has been added as shown in Figure 9. The source impedance in this case is representative of the 'external' system behind bus 2. In this case the terminal parameters of the source are specified, i.e. the desired terminal voltage, P and Q levels at the terminal has to be specified. PSCAD will compute the internal voltage behind the Thevenin impedance which is needed to maintain the specified terminal condition. The positive sequence impedance and negative sequence impedance values are also specified.

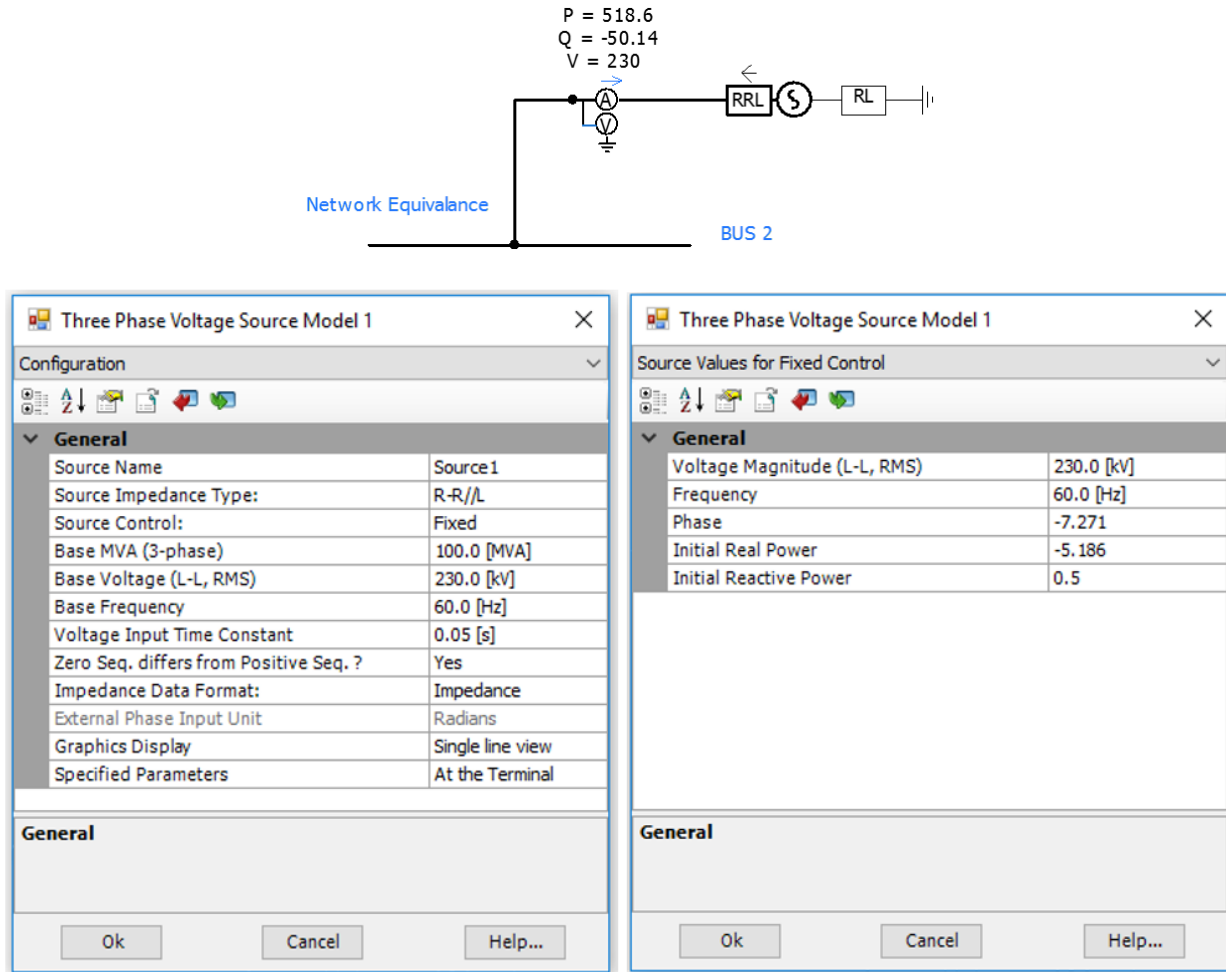

Figure 9: Network equivalence as a non-ideal source

Table 3 shows the power flow between different buses.

Table 3: Power flow between different buses when network equivalent is modeled as non-ideal source

BUS	Real Power (P)	Reactive Power (Q)
1-2	120	-7.625
1-4	27.14	15.89
3-2	398.5	-42.36
3-4	65.68	11.95

Notice that the power transfer remains the same in spite of using a non-ideal source. This validates the power flow equations.

Case 3: With an Actual Generator Model

In this particular case the generator bus (Bus 1) is modeled as a gas turbine-governor system (Figure 10).

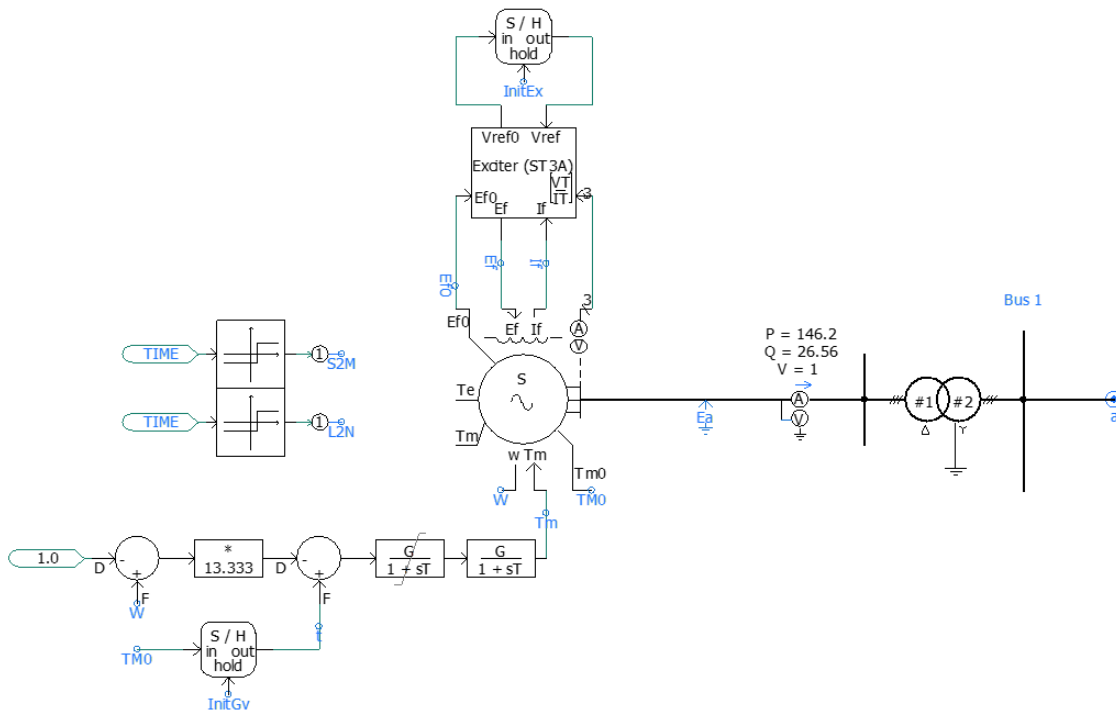

Figure 10: Slack bus modeled as a synchronous generator

The synchronous machine has to be initialized properly. For details on how to initialize a synchronous machine refer to the notes on 'initialization of a synchronous machine'. However for completeness the initialization method has been described briefly.

The machine is initially operated as a pure source (controlled by S2M) and the required field voltage is obtained. The machine is now in locked rotor mode. The exciter then back calculates the reference voltage needed to maintain the specified power levels based on output field voltage of the machine, the field current and the terminal voltage and current of the machine. The gas turbine is represented as a control system that maintains the mechanical torque at the desired level. The mechanical torque required for the specified terminal conditions are calculated by the machine and this value is sampled and held and supplied as the reference. Notice that the torque during the initialization process of the governor is calculated using the speed 'W'. After the rotor is released (controlled by L2M) the torque is then held constant at the reference to provide the mechanical torque necessary to maintain the terminal voltage condition. The power generated by the machine is then injected into the system. A comparison of power transfer between the buses is indicated in Table 4.

Table 4: Buses and their real power and reactive power

BUS	Real Power (P)	Reactive Power (Q)
1-2	117.5	-8.749
1-4	26.42	15.55
3-2	399.1	-42.19
3-4	66.23	12.24

In spite of the varying levels of complexity added to the system, the underlying principle of power transfer is satisfied in each case. Figure 11 shows the comparison of real and reactive power at the load bus for all the three cases.

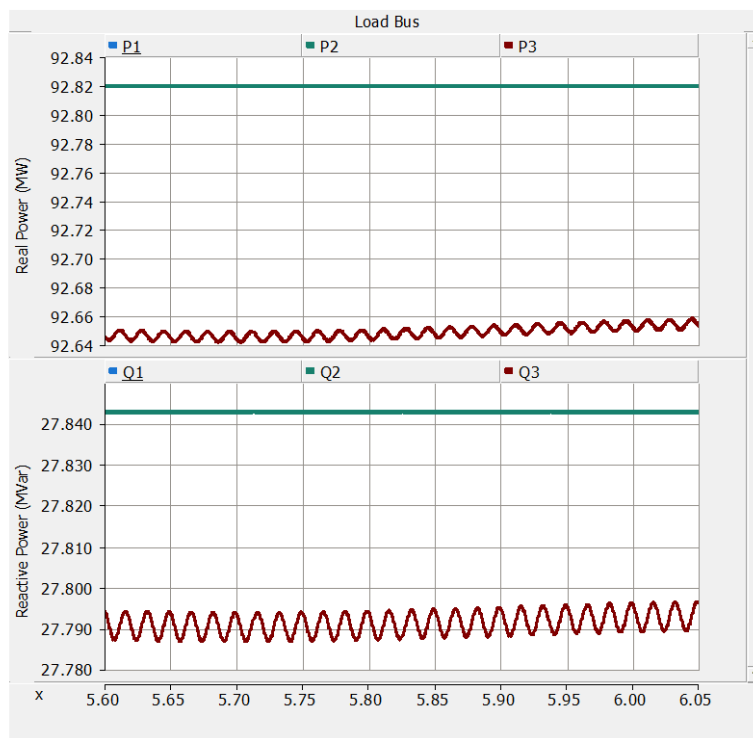

Figure 11: Comparison of real and reactive power

PSCAD simulation 2

Refer to PSCAD case: *Load_Flow_02.pscx*

System Overview

Load flow studies require that each bus can be classified either as a: slack bus, PV bus, or load bus. Figure 12 below shows a simple 3 bus system with a slack bus, a PV bus, and a load bus. Each transmission line can then be modelled with either PI sections or a more detailed transmission line model. Multimeters are placed throughout the network to show the bus voltages and real and reactive power. The slack bus (or slack node) is set to maintain the bus voltage at 1 PU and 0° . The PV bus is set to maintain the voltage magnitude at 1 PU and generate 15 MW of power. The load bus draws 45 MW of real power and 15 MVAR of reactive power.

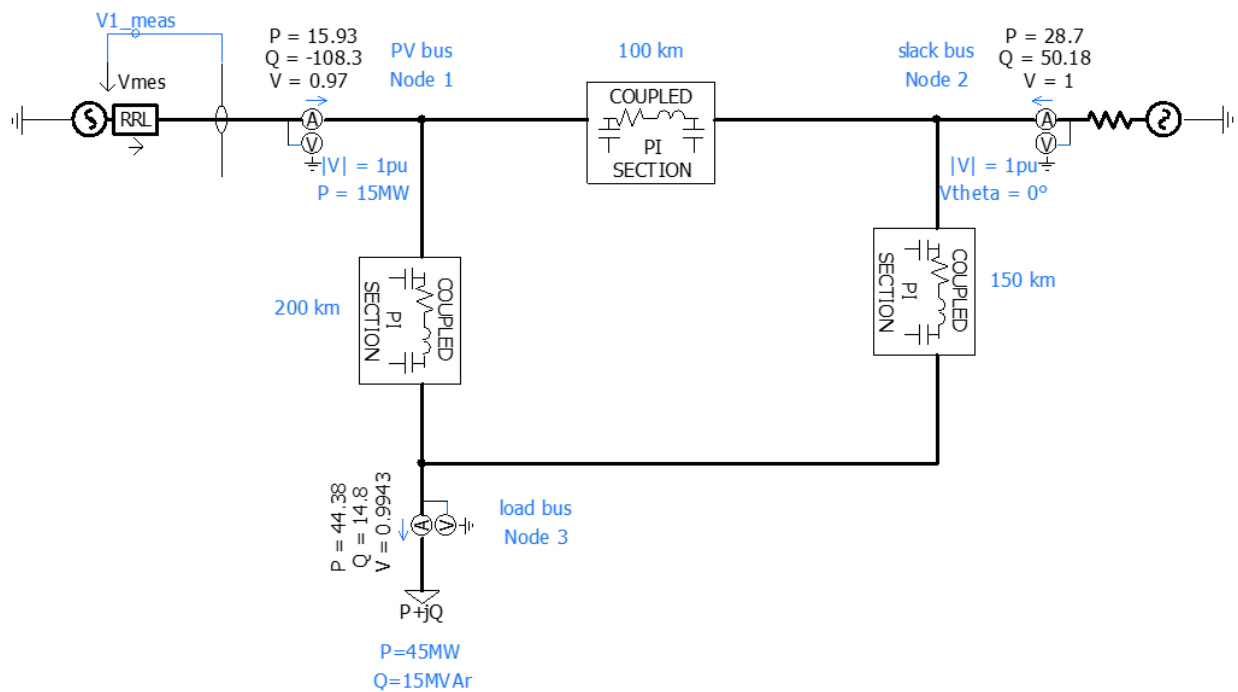

Figure 12: Case Circuit

Slack Bus

A slack bus is the reference bus and has a pre-specified voltage magnitude and angle (typically 1 PU and 0°). In PSCAD you can use the 'Three Phase Voltage Source Model 2' as the generator on the slack bus. You specify the desired terminal voltage and phase angle, and PSCAD will maintain those values during the simulation. Figure 13 below shows how to configure the slack bus.

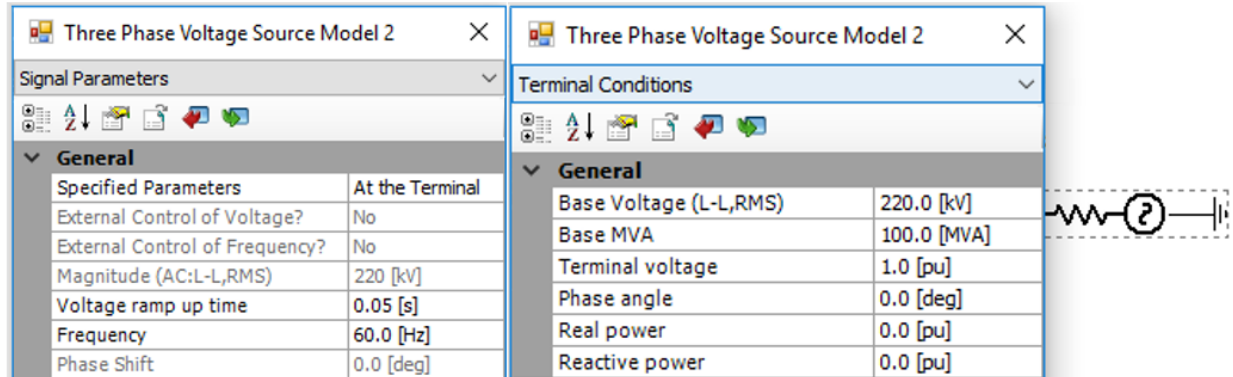

Figure 13: Slack Bus Configuration

PV Bus

The real power and voltage magnitude are known for a PV bus. To make a PV Bus, the 'Three Phase Voltage Source Model 1' can be used. In the object editor, the Automatic Source Control is enabled and under "Automatic Voltage Control", Enable Automatic Voltage Control is set to YES. Then you can set the desired bus voltage magnitude. Under "Automatic Power Control", set Enable Automatic Power Control to YES, and input the desired output power. Note that you may have to increase the Controller Time Constant to get desirable results if the controller is acting too fast and giving unrealistic results. Finally, you must provide voltage feedback to the voltage source so it can regulate the voltage. Figure 14 below shows the dialog boxes that need to be edited, and also how the Three Phase Voltage Source should be connected.

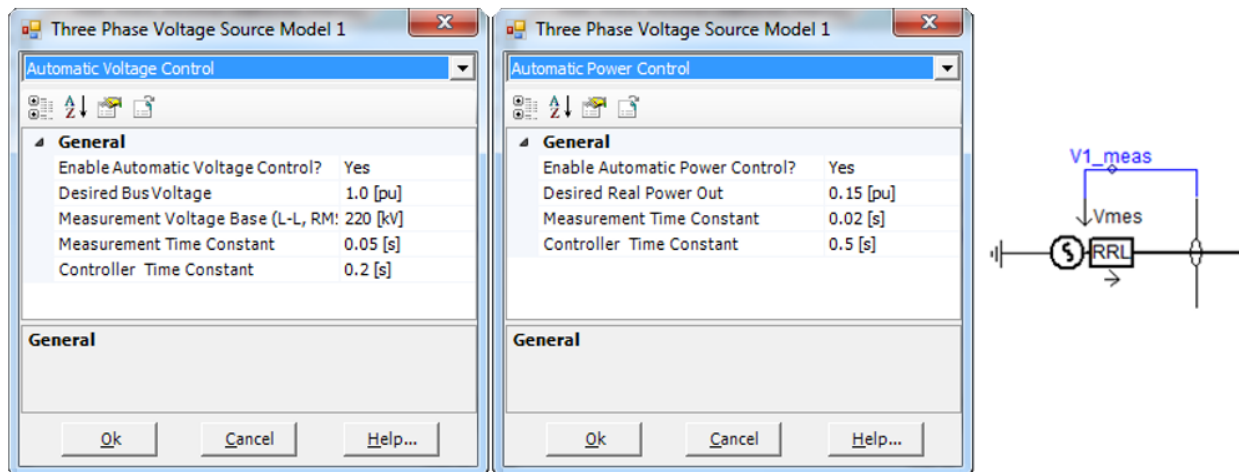

Figure 14: PV Bus Configuration

Load Bus

A load bus is where the real and reactive power are known. The 'Fixed Load' component can be used to set up a load bus. Inside the object editor, the real and

reactive power (per phase) consumes by the Fixed Load can be identified as shown in Figure 15.

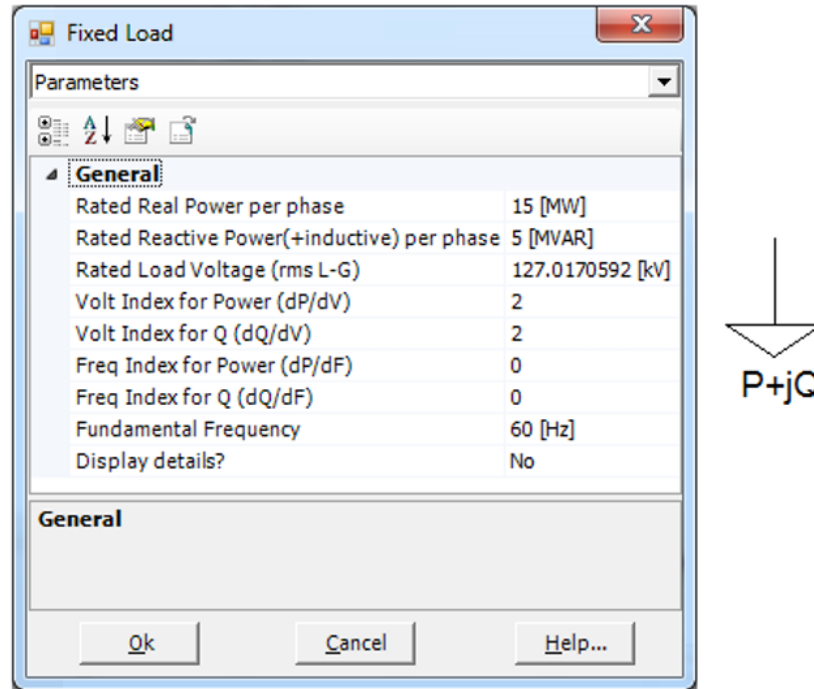

Figure 15: Load Bus Configuration

Simulation Results

The meters in the Figure 16 show the final steady-state values for all bus voltages and magnitudes. It also shows the real and reactive power injected into each bus. Bus 1 is the PV bus, and it's observed that the voltage magnitude is 1 PU and power output is 15MW. The simulation reveals that the bus 1 angle is -0.093° and must absorb 108.323 MVAR. The remaining meters show rest of the results required from a load flow study.

Control Panel									
V1	theta1	P1gen	Q1	V2	theta2	P2	Q2	Vload	thetaLoad
0	220	-200	100-20	200	220	-200	200	200	2-20
0.96996	0.093231	15.9287	-108.323	0.999999	2.02337e...	28.6993	50.1797	0.994275	-1.23088

Figure 16: Steady-State Bus Values and Powers

One difference between PSCAD and dedicated LFA programs such as PSS/e is that PSCAD also performs transient calculations. Figure 17 shows how the PV bus generator acts to maintain its desired output. Such transient dynamics would not be seen in a typical LFA program.

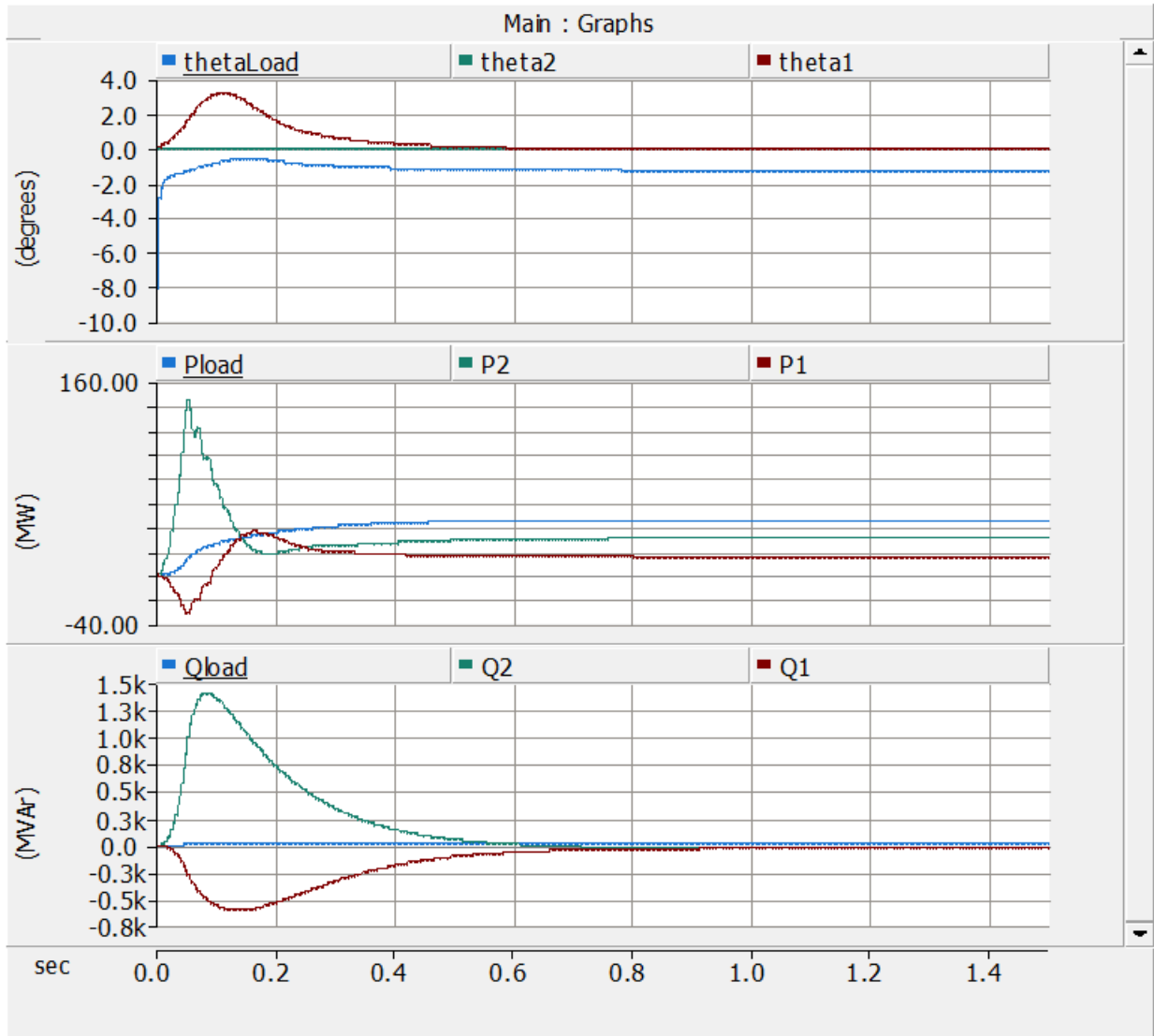

Figure 17: Simulation transients before reaching the steady-state condition

DOCUMENT TRACKING

Rev.	Description	Date
0	Initial	29/May/2015
1	Rev. 1	03/Jan/2018