

PSCAD V5 offers new parallel-processing capabilities to maximize the power of multi-core computers.

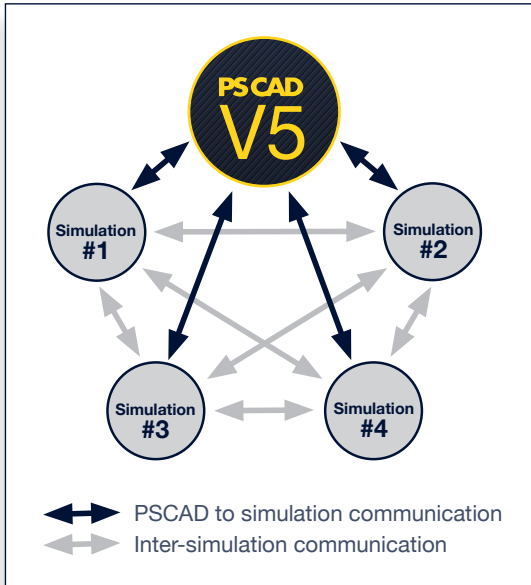

Parallel Simulations Using PNI

PSCAD™ employs parallel processing techniques by running simulations on both a single, multi-core computer, or on a cluster of computers connected via a LAN or high-speed interconnect (e.g., InfiniBand), to significantly reduce simulation times. The following fast inter-process communication protocols are now supported:

- Shared memory;
- Remote Direct Memory Access (RDMA) over InfiniBand*.

Parallel Network Interface (PNI)

Using the Parallel Network Interface (PNI), a large power network model can be broken into smaller sub-networks, inter-connected and simulated in parallel:

- Individual sub-networks run on a separate processor core.
- Values are exchanged via an inter-process communication interface.
- Overall simulation time is drastically reduced as compared to running one large network on a single core.

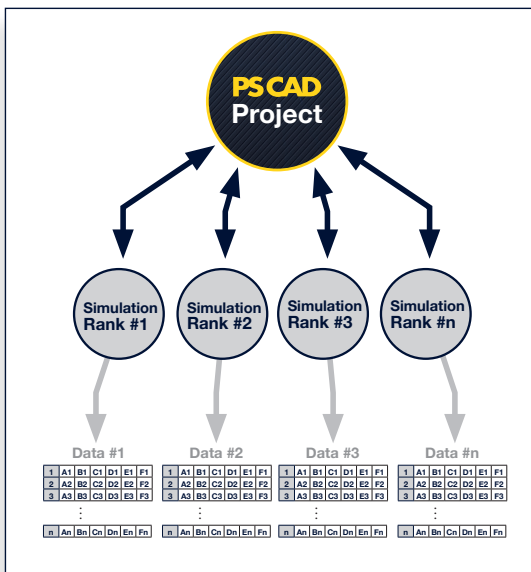

Parametric Study Using PMR

Parallel Multiple Run (PMR)

Intense studies that require running a project simulation many times to evaluate different conditions can be performed using Parallel Multiple Run (PMR), for example:

- Parametric studies and multiple scenarios;
 - Renewable integration studies.
 - Transient Switching studies.

The simulations are run simultaneously (launched as a volley) over multiple processor cores, on one or more computers, thereby obtaining significantly faster results than running them sequentially on a single core.

* Special hardware is required for RDMA over InfiniBand

Intelligent Parallel Multiple-Run (PMR-I)

With the Intelligent Parallel Multiple-Run (PMR-I), a Master/Slave based, parallel simulation paradigm that allows for a single master project to control multiple slave projects. The idea behind this feature is to support both parametric, as well as optimization-based, multiple-run studies:

- Inter-project communication is achieved by using the already well-defined radio link components.
- Communication between projects is performed only between runs;
 - The master project distributes the control parameters to the slaves.
 - The slaves send result data back to the master (via radio links).

Cluster Launch System (CLS)

The Cluster Launch System (CLS) facilitates the launching of simulations on remote computers:

- Allows the user to configure the PSCAD computing environment by adding more networked computers to increase the number of cores.
- Launches simulations on remote networked computers with a click of the mouse.

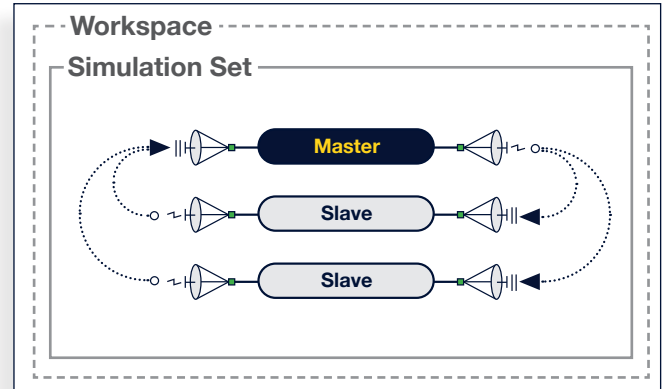

Master/Slave Parallel Simulation Using Radio Links

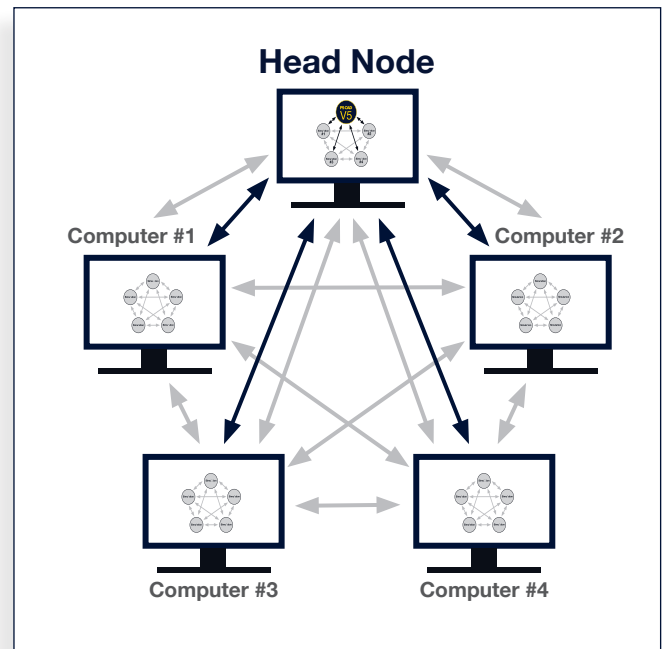

Cluster Launch System (CLS)

See examples at pscad.com/knowledge-base

At PSCAD, we are committed to providing our clients with world-class training. As a new user, our team of experts will tailor a course to suit your needs, either from your office or at our professional training environment.

PSCAD™ is more than just an electromagnetic transients simulation tool. Our community of specialized engineers and computer scientists are eager to share an expanse of knowledge to help contribute to your success.