

Lightning Studies



Dharshana Muthumuni, Managing Director



Lalin Kothalawala, Manager: Simulation & Design Analysis

- Lightning – Injection of electric charge (current) into a power system component (tower, line, shield wire).
 - Very short duration (impulse – 50us – 100 us)
- The circuit impedances will determine the induced voltage levels at different locations near the point of strike.

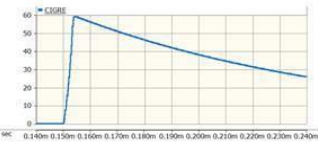
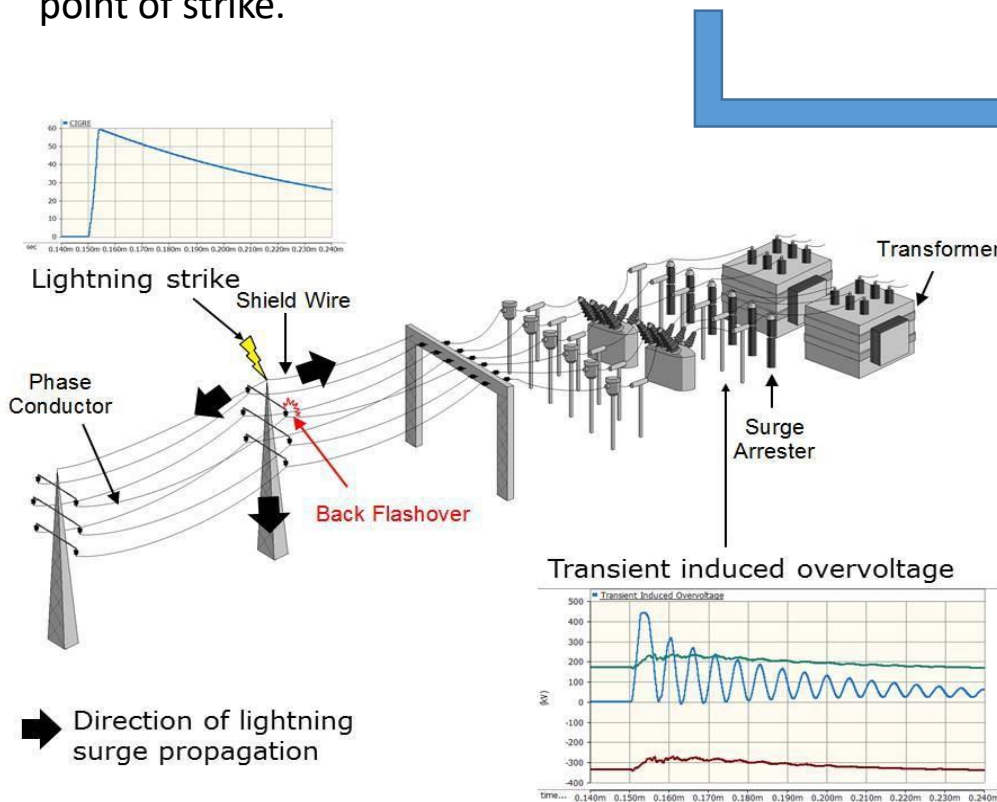

$$V = I * Z$$

$$v = L \frac{di}{dt}$$

- The impacts of the lightning event are limited to a local area around the point of the lightning strike

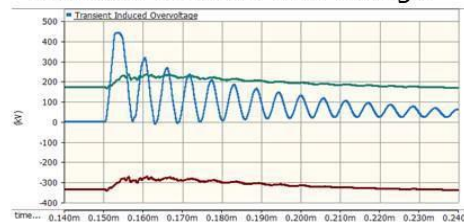

- Lightning induced over voltage can be a result of a direct strike to a phase conductor (shielding failure) or due to 'back flashover' resulting from a lightning strike on a shielding (ground wire) wire.
- Both events would cause transient voltage escalations at the terminals of station equipment.
- The study will identify the severity of such transients. It will also identify the required rating and location of surge arresters to ensure that such over voltages do not exceed the insulation strength of the main equipment.
- A lightning overvoltage study requires the detailed modeling of the substation equipment (including natural or stray capacitance of equipment), the station bus bars, and a few spans of the adjacent transmission towers.

Direct strike on a phase

conductor:

This is due to 'smaller' lightning strokes that escape the shielding. Typically, the magnitude of the lightning current surge is in the 8 kA – 12 kA peak.

Back Flash over:

Lightning strikes (surge current) the ground wires. The current discharges to ground through the tower and the 'tower footing resistance'. The resulting potential rise of the tower stresses the line insulation. If the voltage stress exceeds thresholds, flashover happens.

$V_t - V_{sys} > \text{gap flashover voltage?}$

$$V_t = f(I_x, Z_t, Z_g)$$

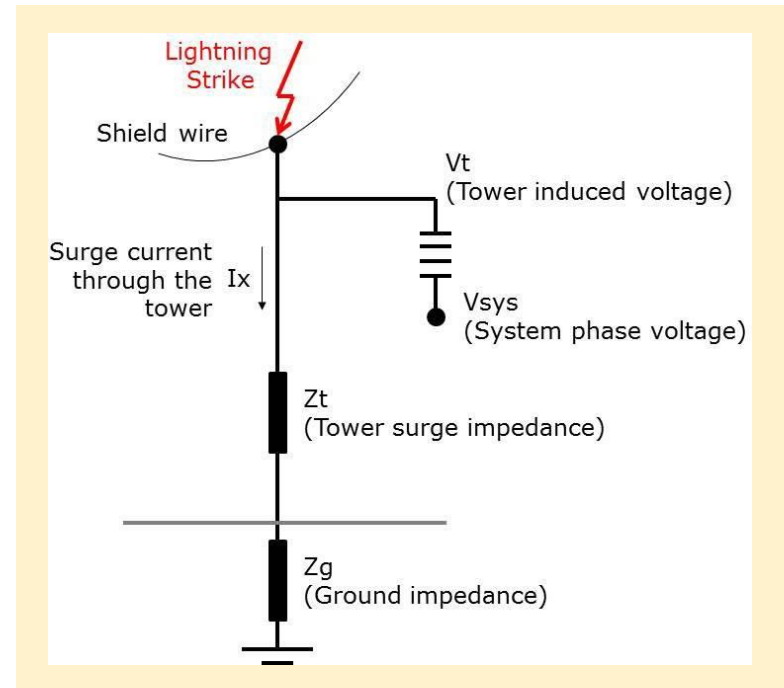

- How often will a line flashover per year?
- Do we need Transmission Line Surge Arresters (TLSAs)?
- At the end of the line, what overvoltage levels are experienced by the station equipment?
- Station surge arresters:
 - Are the selected arresters adequate to limit over voltages?
 - Can arresters handle in the energy associated with lightning event?

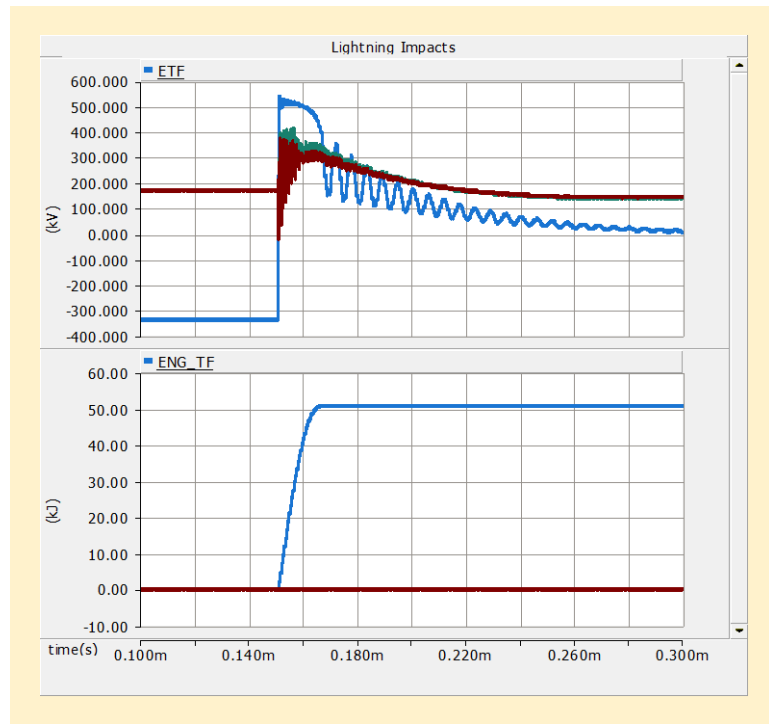
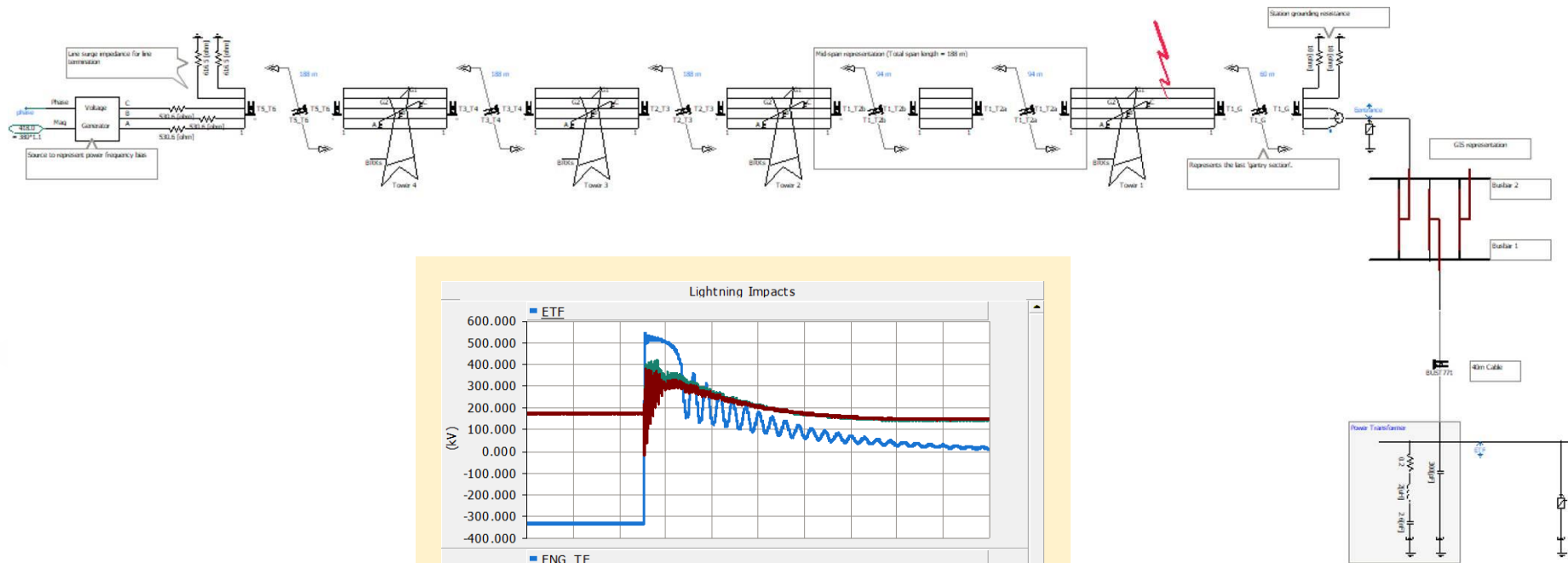

PSCAD Study Model – Estimate critical flashover current to determine (expected) line flashover rate

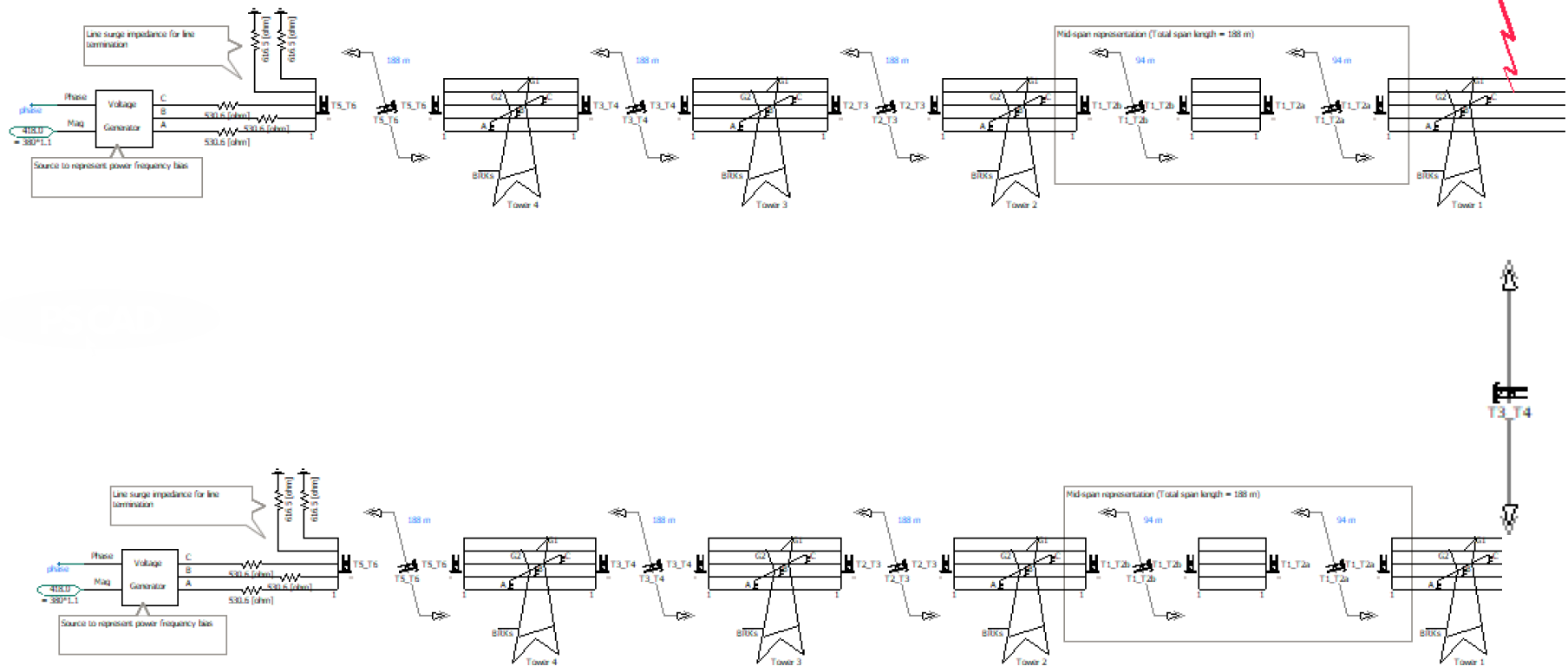

- Typically modeled as an injection of a current impulse.
 - Impulse magnitude will impact the over voltage experiences at station transformers and other equipment.
 - Impulse rise time (di/dt) will impact the over voltage impressed at station transformers and other equipment.
- Thus, it is important to judiciously select the impulse parameters for the study.
 - IEEE and CIGRE guidelines

Direct strike – 8 – 15 kA peak impulse current

Strike on ground wires – 80kA – 200 kA

- 200 kA is considered highly unlikely.

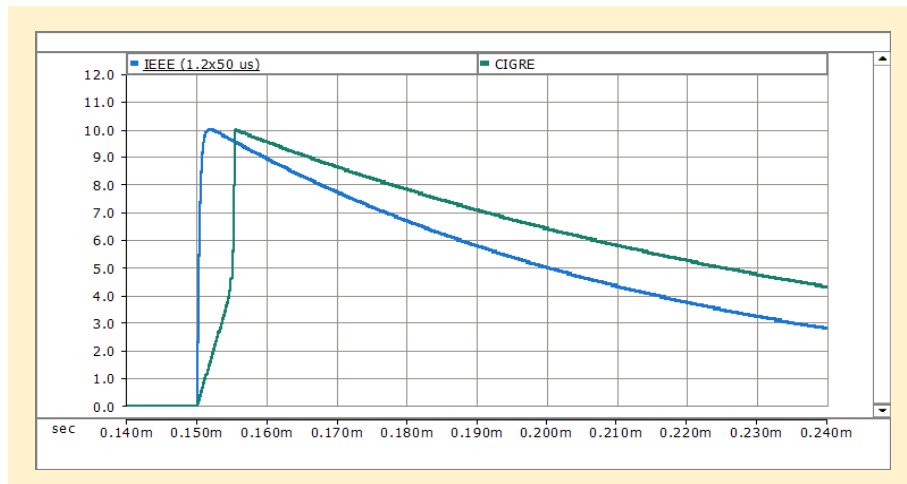

The peak current is estimated based on guidelines provided in IEEE/CIGRE documents.

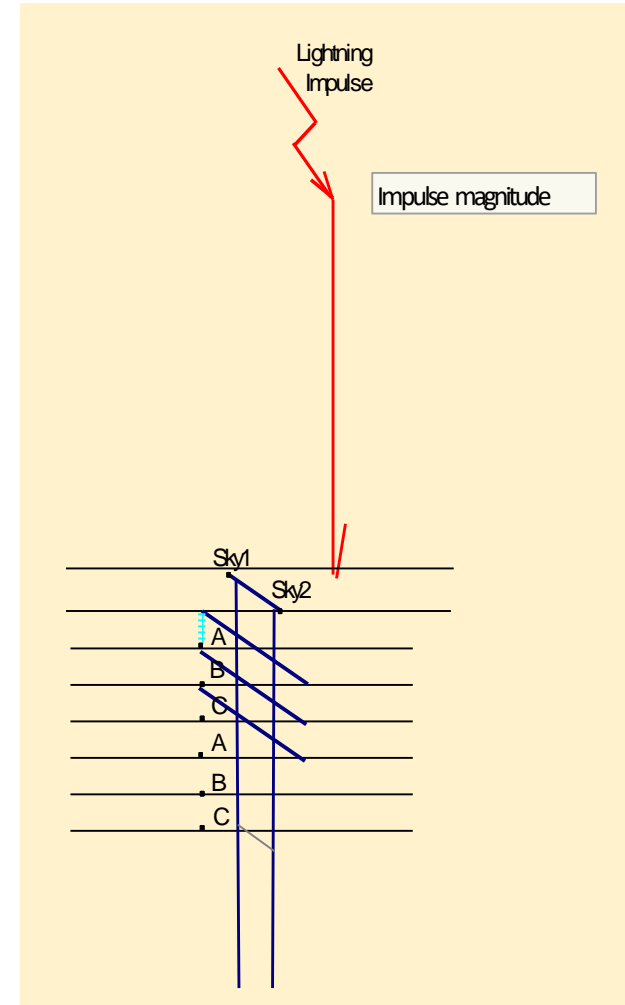

How do we represent the lines and towers:

Typically only a few tower spans needs to be included in a lightning over voltage study model

- The tower sections are represented as traveling wave line sections (surge impedance based on tower type – 150 Ohms for 380 kV typical)
- Tower spans modeled based on tower/conductor geometry/data.
- Insulators represented by an equivalent capacitance
- Tower footing resistance is a important parameter for the study
 - Sensitivity check for 5 Ohm – 25 Ohm typical.

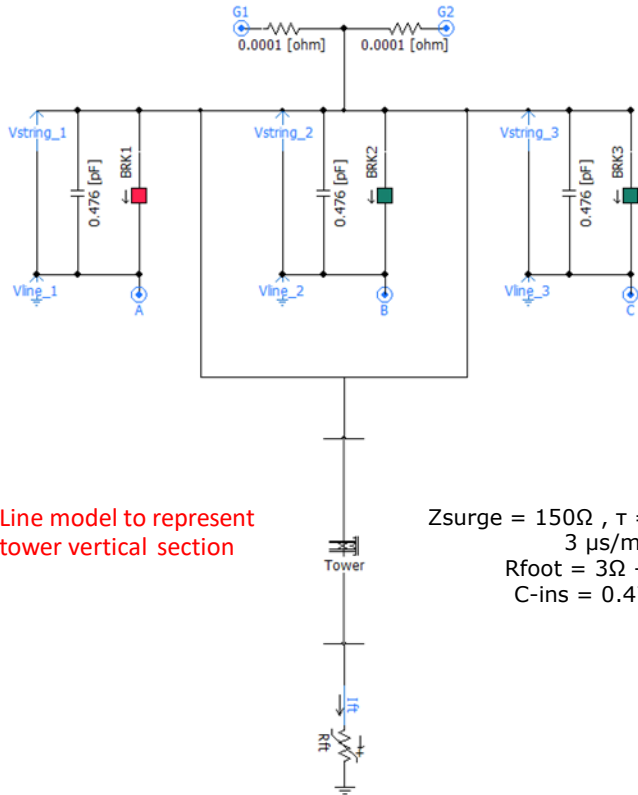

Line model to represent tower vertical section

$Z_{surge} = 150\Omega$, $\tau = 3.448 \times 10^{-3} \mu s/m$
 $R_{foot} = 3\Omega - 20\Omega$
 $C_{-ins} = 0.476 pF$

Tower Representation

Note: Back flashover is modeled by closing the (fictitious) circuit breaker when the voltage across the insulator crosses a threshold.

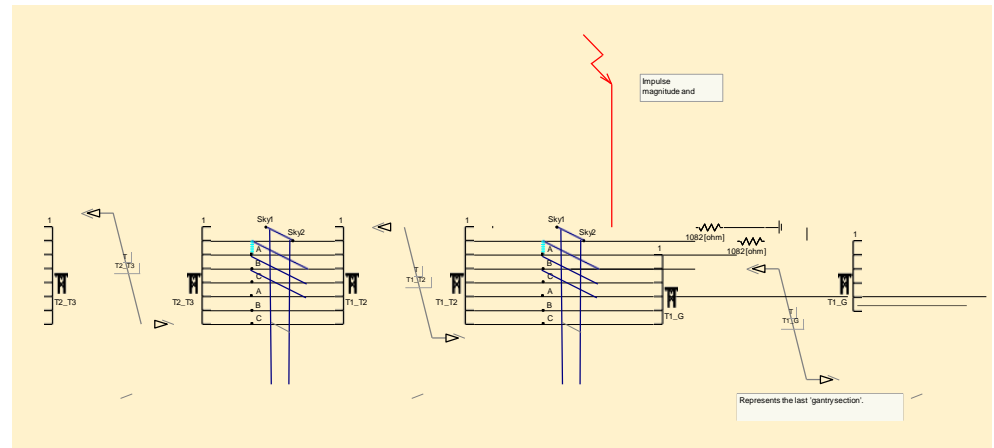

Tower spans

Note: After about 5 spans, the rest of the line is represented by a resistance approximately equal to the surge impedance of the conductors (phase and ground).

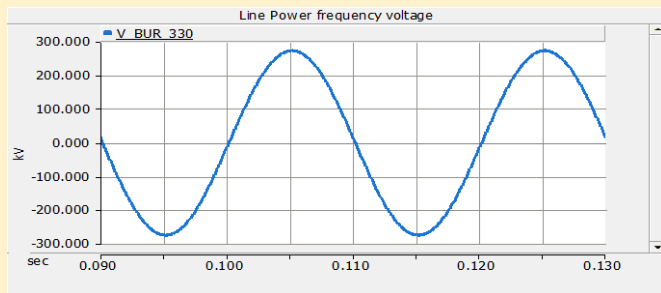
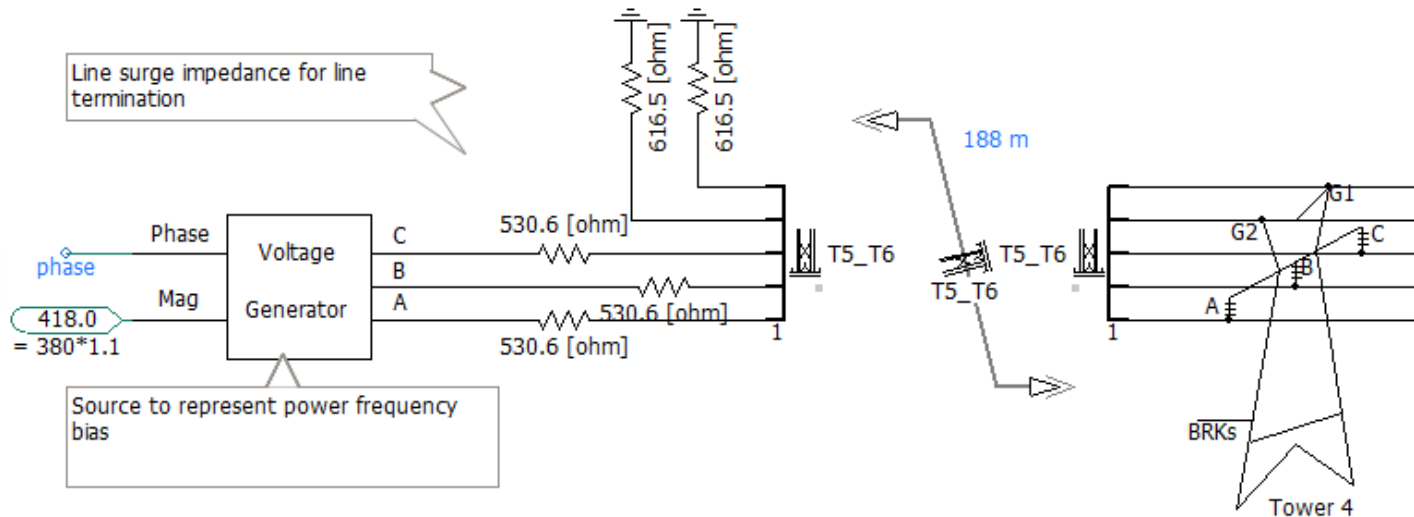

The lightning strike can happen at any instant (at any voltage point on the power frequency waveform)

Volt-Time Method:

If the voltage across the insulator exceeds the insulator voltage withstand capability, back flashover occurs (simulated by closing the parallel switch).

Breakdown of air as an insulator is mostly a function of environmental conditions, in addition to the fast-front voltage build-up.

An expression for the insulator voltage withstand capability:

$$V_{f0} = K_1 + \frac{K_2}{t^{0.75}}$$

Lead Progression Method:

Back flashover occurs when a leader propagating from one electrode reaches the other, or when leaders propagating from both electrodes meet in the middle of the air gap.

$$\frac{dl}{dt} = k \cdot v(t) \left[\frac{v(t)}{d_G - l} - E_0 \right]$$

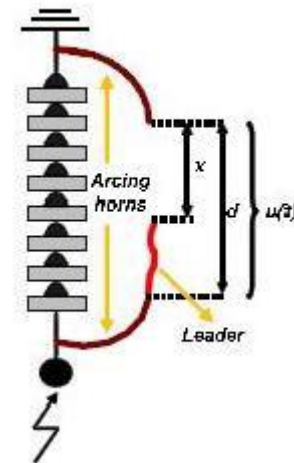

Station and equipment representation:

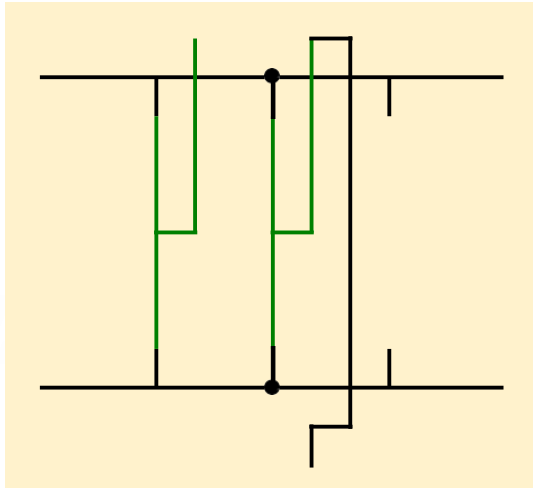

Station model – Top level view

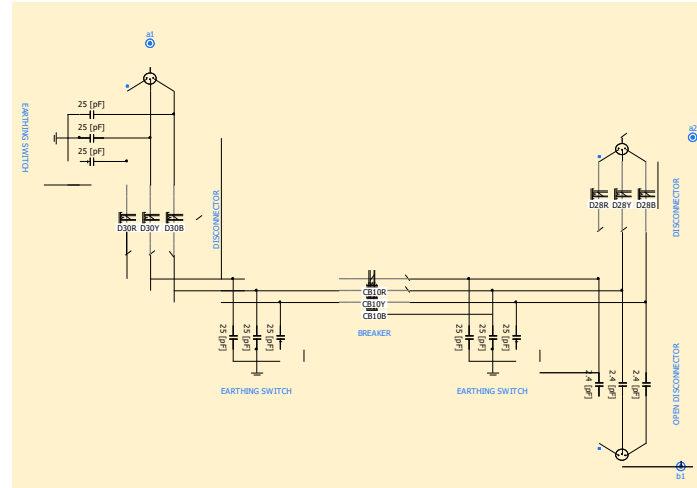

Station model – Model details

Sub station buses and equipment should be represented in a manner suitable for this high frequency phenomena

- Bus sections – represented by traveling wave line models
- Equipment – represented by respective stray/bushing capacitances
 - Typical values available in IEEE publications.

Sub station buses and equipment should be represented in a manner suitable for this high frequency phenomena

- Transformer – represented by respective stray/bushing capacitances
- Surge Arrester – V-I characteristics and lead inductances

Alternative representation of station transformer

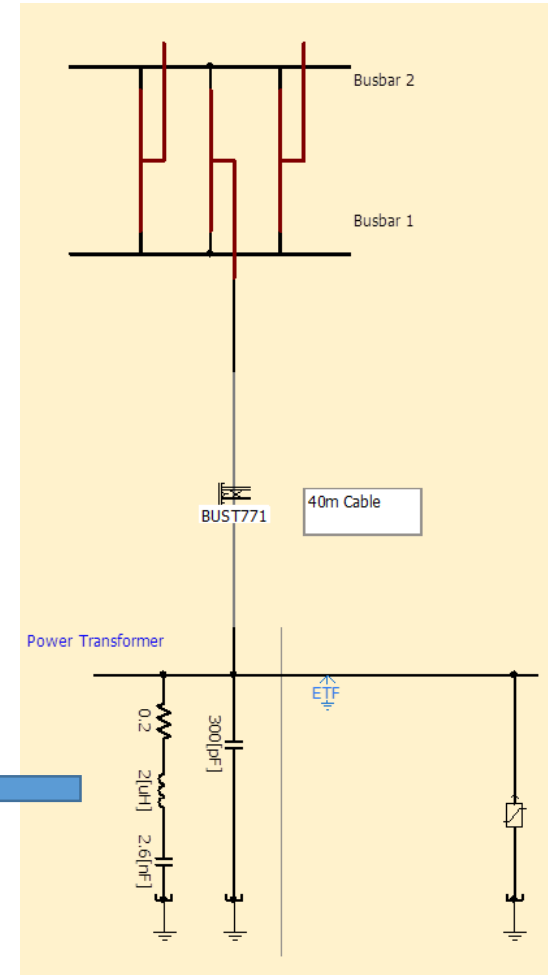
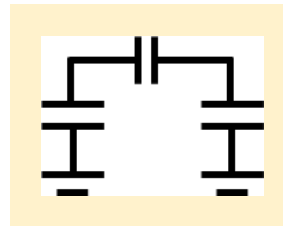

Critical Backflashover Current

- **Station:**
 - Surge arrester's location and energy rating.
 - Induced overvoltage at the transformer and other major equipment.
- **Line design:**
 - Adequacy of tower design (i.e. clearance, grounding, etc.)

The PSCAD logo consists of the word "PSCAD" in a bold, blue, sans-serif font, enclosed within a white oval shape. A small mouse cursor arrow is positioned at the bottom left of the oval.

PSCAD

PSCAD Simulation Example

The PSCAD logo consists of the text "PSCAD" in a bold, blue, sans-serif font, enclosed within a white oval shape. A small mouse cursor arrow is positioned at the bottom left of the oval.

PSCAD

Thank you