

TRAINING

Lightning Studies



Overview of Presenters



Dharshana Muthumuni, Managing Director



Lalin Kothalawala, Manager: Simulation & Design Analysis



Arash Darbandi, Power System Simulation & Design Engineer

BACKGROUND:

Lightning induced over voltage can be a result of a direct strike to a phase conductor (shielding failure) or due to 'back flashover' resulting from a lightning strike on a shielding (ground wire) wire. Both events would cause transient voltage escalations at the terminals of station equipment. The study will identify the severity of such transients. It will also identify the required rating and location of surge arresters to ensure that such over voltages do not exceed the insulation strength of the main equipment.

A lightning overvoltage study requires the detailed modeling of the substation equipment (including natural or stray capacitance of equipment), the station bus bars, and a few spans of the adjacent transmission towers.

Background

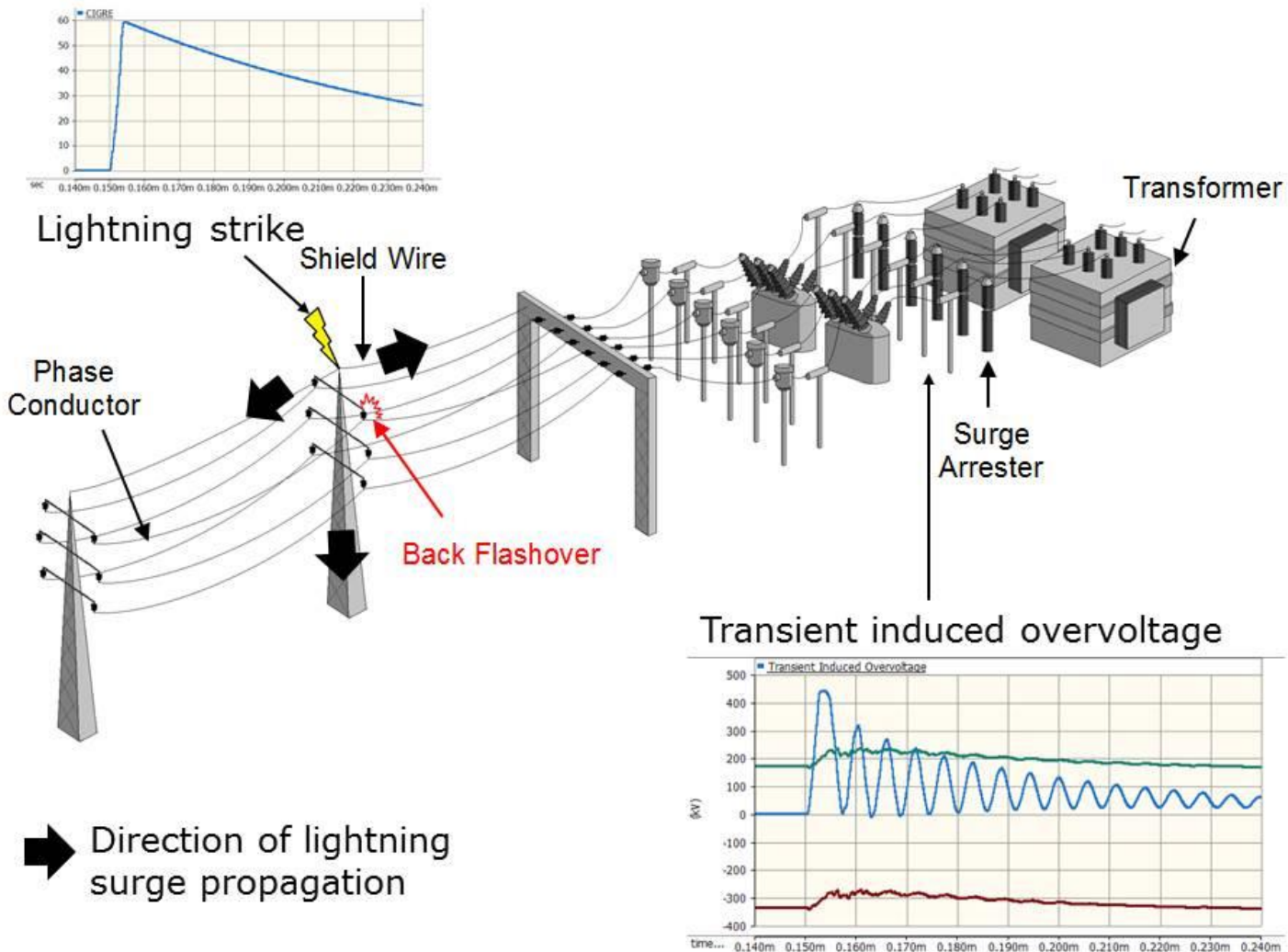

Direct strike on a phase conductor:

This is due to 'smaller' lightning strokes that escape the shielding. Typically, the magnitude of the lightning current surge is in the 8 kA - 12 kA peak.

Back Flash over:

Lightning strikes (surge current) the ground wires. The current discharges to ground through the tower and the 'tower footing resistance'. The resulting potential rise of the tower stresses the line insulation. If the voltage stress exceeds thresholds, flash over happens.

$$V_t - V_{sys} > \text{gap flashover voltage?}$$
$$V_t = f(I_x, Z_t, Z_g)$$

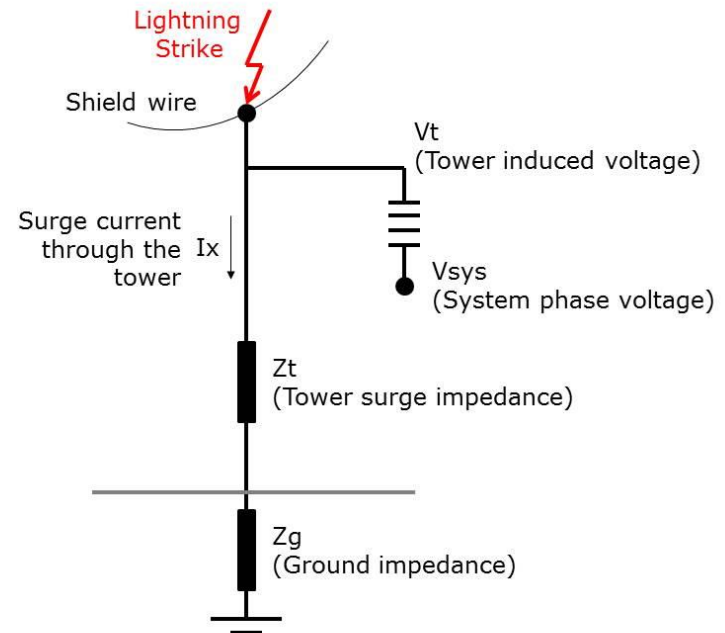

Why perform Lightning studies?

- How often will a line flashover per year?
- Do we need Transmission Line Surge Arresters (TLSAs)?
- At the end of the line, what overvoltage levels are experienced by the station equipment?
- How to choose an adequate surge arrester and where should it be located?

PSCAD Model Developments

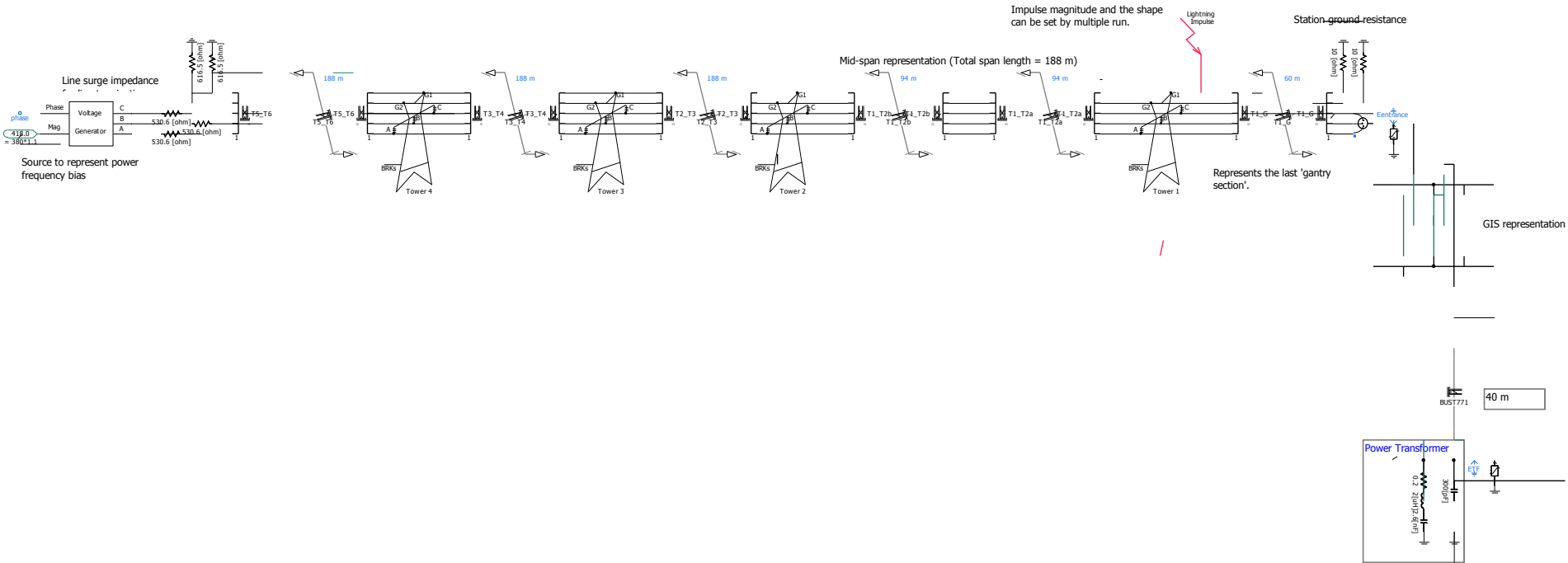

How do we represent the lightning stroke in a simulation study:

Typically modeled as an injection of a current impulse.

- Impulse magnitude will impact the over voltage experiences at station transformers and other equipment.
- Impulse rise time (di/dt) will impact the over voltage impressed at station transformers and other equipment.

Thus, it is important to judiciously select the impulse parameters for the study.

- IEEE and CIGRE guidelines

How do we represent the lightning stroke in a simulation study:

Direct strike – 8 -15 kA peak impulse current

Strike on ground wires- 80kA – 200 kA

- 200 kA is considered highly unlikely.

In a study, the Lightning impulse is modelled as a current source with a typical wave shape.

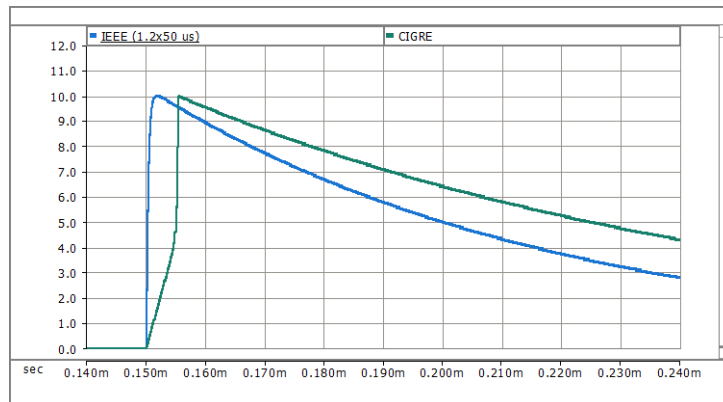

For direct stroke and back flashover, the peak current is estimated based on guidelines provided in IEEE/CIGRE documents.

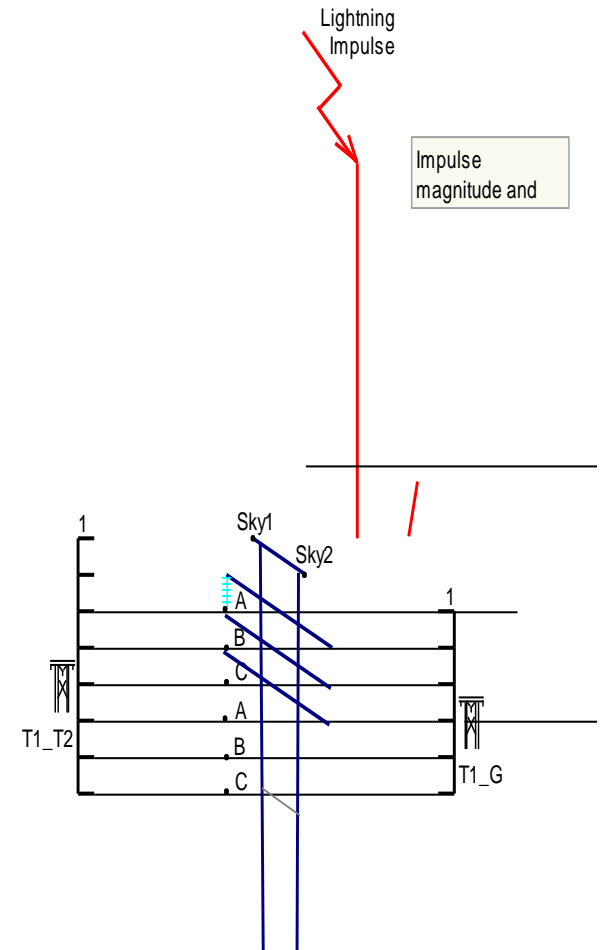

How do we represent the lines and towers:

Typically only a few tower spans needs to be included in a lightning over voltage study model

- The tower sections are represented as traveling wave line sections (surge impedance based on tower type – 150 Ohms for 380 kV typical)
- Tower spans modeled based on tower/conductor geometry/data.
- Insulators represented by an equivalent capacitance
- Tower footing resistance is a important parameter for the study
 - Sensitivity check for 5 Ohm – 25 Ohm typical.

How do we represent the lines and towers:

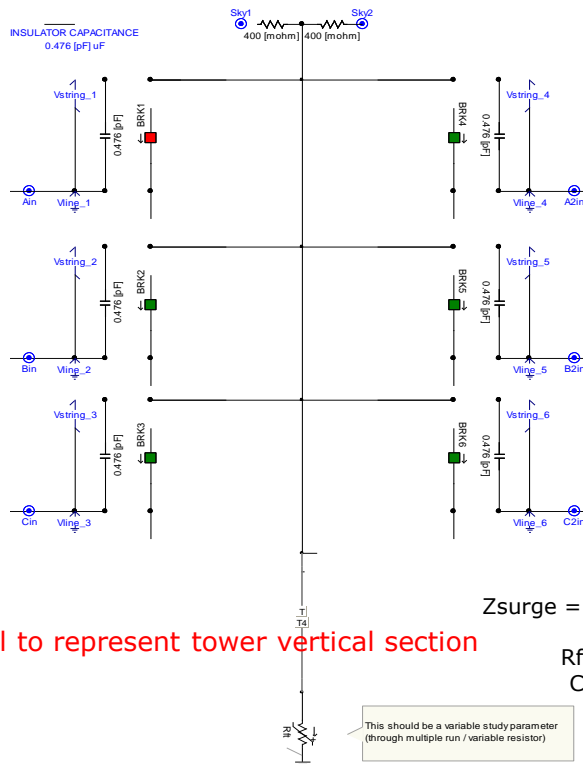

Line model to represent tower vertical section

$Z_{\text{surge}} = 150\Omega$, $\tau = 3.448 \times 10^{-3} \mu\text{s/m}$
 $R_{\text{foot}} = 3\Omega - 20\Omega$
 $C_{\text{-ins}} = 0.476\text{pF}$

This should be a variable study parameter (through multiple run / variable resistor)

Tower Representation

Note: Back flashover is modeled by closing the (fictitious) circuit breaker when the voltage across the insulator crosses a threshold.

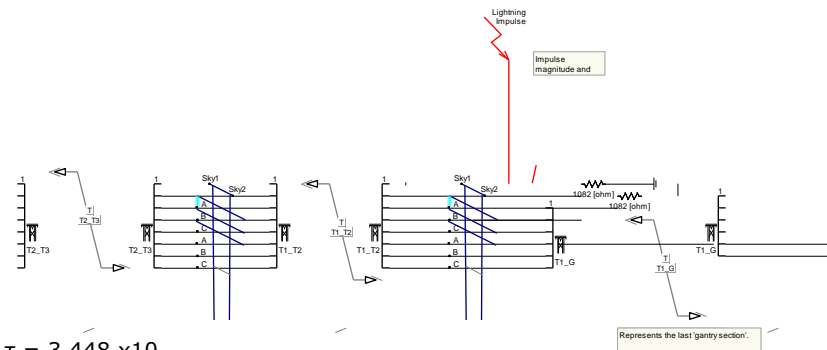

Tower spans

Volt-Time Method:

If the voltage across the insulator exceeds the insulator voltage withstand capability, back flashover occurs (simulated by closing the parallel switch).

Breakdown of air as an insulator is mostly a function of environmental conditions, in addition to the fast-front voltage build-up.

An expression for the insulator voltage withstand capability:

$$V_{f0} = K_1 + \frac{K_2}{t^{0.75}}$$

Lead Progression Method:

Back flashover occurs when a leader propagating from one electrode reaches the other, or when leaders propagating from both electrodes meet in the middle of the air gap.

$$\frac{dl}{dt} = k \cdot v(t) \left[\frac{v(t)}{d_G - l} - E_0 \right]$$

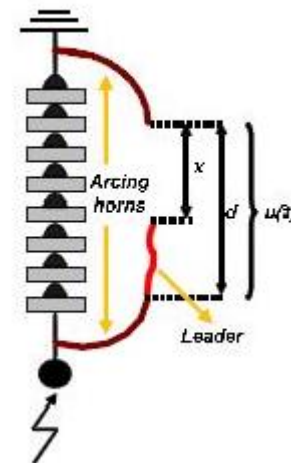

Station and equipment representation:

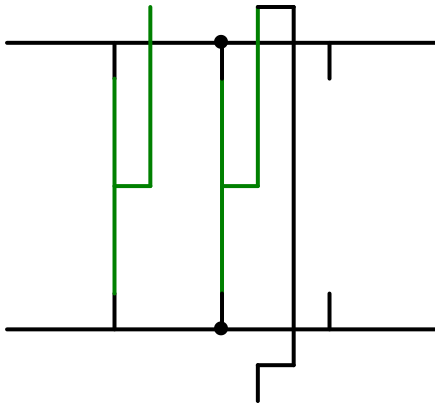

Station model – top level view

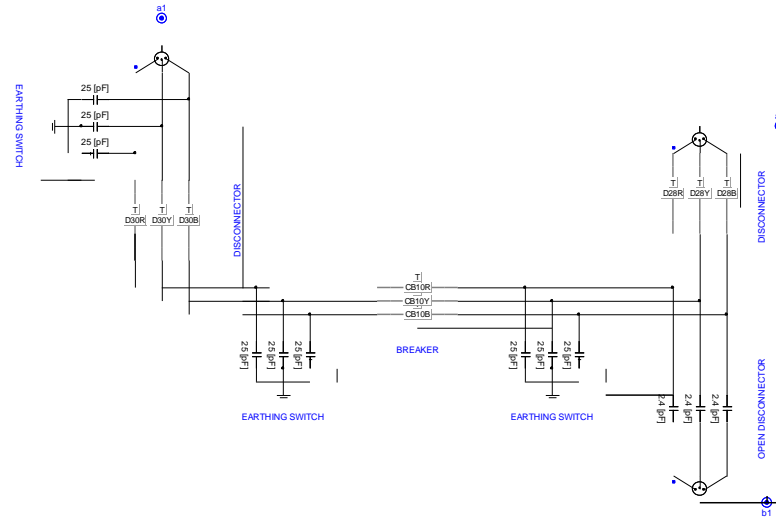

Station model – Model details

Sub station buses and equipment should be represented in a manner suitable for this high frequency phenomena

- Bus sections – represented by traveling wave line models
- Equipment – represented by respective stray/bushing capacitances
 - Typical values available in IEEE publications.

Station and equipment representation:

Sub station buses and equipment should be represented in a manner suitable for this high frequency phenomena

- Transformer – represented by respective stray/bushing capacitances
- Surge Arrester – V-I characteristics and lead inductances

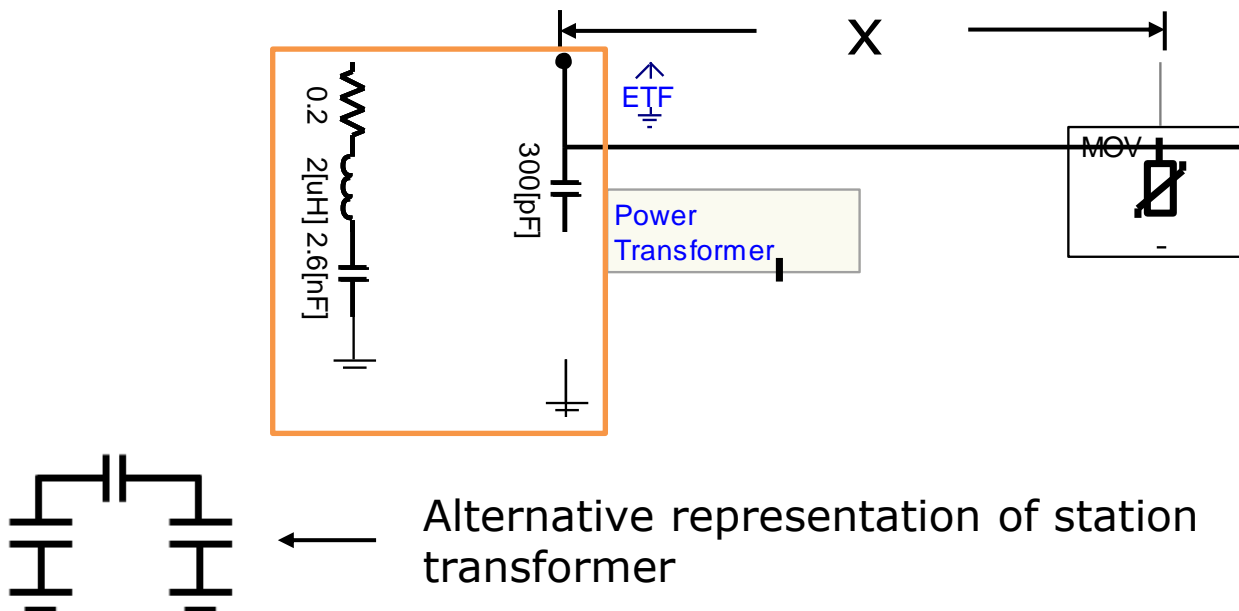

Study Outcomes:

- Critical Backflashover Current.
- Surge arrester's location and energy capability.
- Transient induced overvoltage at the transformer and other major equipment.
- Adequacy of tower design (i.e. clearance, grounding, etc.)

PSCAD Simulation Example

Thank you