

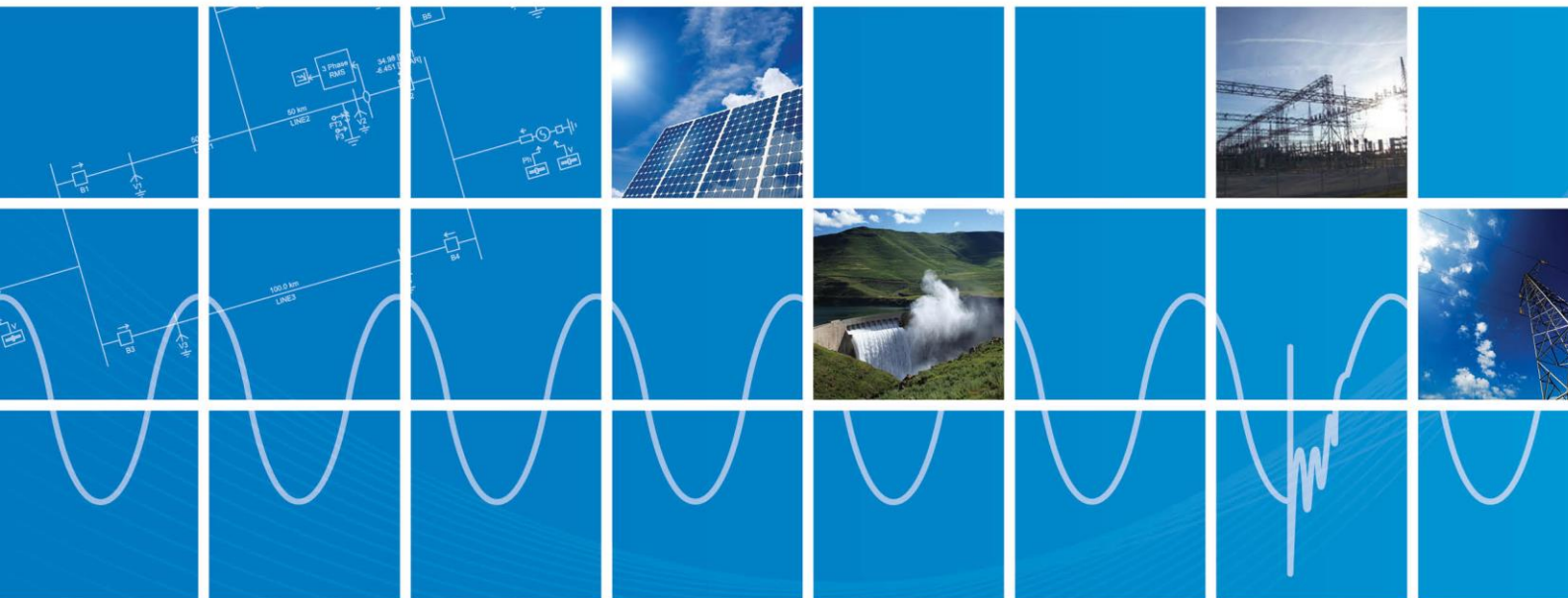

Tutorial : Power Quality

Network Harmonic impedance scans and harmonic distortion

October 3, 2018
Revision 1



Objective(s):

- Using the Network harmonic Impedance component
- Identifying network resonances
- Harmonic voltage amplification due to non linear loads.

Application of 'network harmonic impedance scanning' methods to identify possible voltage distortion issues.

Part 1: Load the case *HV_test_system.pscx*

- Measure the harmonic impedance at bus 15.
- Use 'Livewire' to plot the positive sequence impedance as a function of frequency.
- Identify the resonance points.
- Add 300 MVARs of capacitive reactance to bus 15 and see how the harmonic impedance profile is affected.
- Note how the resonance points have shifted.
- Harmonic resonances can cause sustained over voltages and harmonic voltage distortions in networks.

Part 2: Load the case *Harmonic_voltage_dist.pscx*:

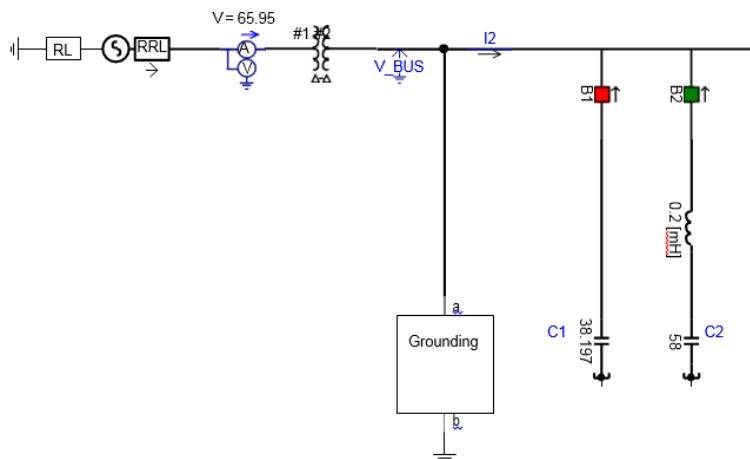

Figure 1. Simple network model of a distribution network

Observe the harmonic impedance profile of this simple system, measured at the capacitor bus. Consider the following conditions:

- No capacitor bank
- Both banks in service
- Only bank C1 in service
- Only bank C2 in service

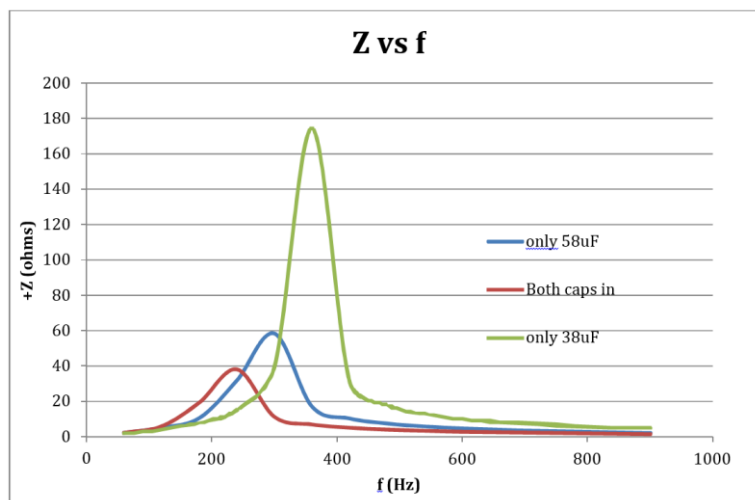

Figure 2. Harmonic impedance profile with bank C1 in service

- Observe the voltage harmonic at the bus bar and verify the harmonic distortion for each case and verify the results.
- If transformer saturation is 'disabled' would you observe voltage distortions? Explain the observation.